



Drainage systems

TECEdrainpoint S

TECHNICAL INFORMATION



TECE:

All data contained in the Technical Information has been compiled with the utmost care. However, the correctness of the data presented cannot be guaranteed. TECE assumes no liability for damage resulting from the use of this information. Text and images are protected by copyright law.

Issue: March 2020

© Copyright 2020, TECE GmbH, Hollefeldstraße 57, D-48282 Emsdetten

Contents

Introduction	3-4
Planning	3-5
Sealing	3-5
Connection of composite seals to floor drains, shower channels and profiles	3-5
Seal System – Tested composite seal	3-5
Drains	3-7
Load-bearing capacity of grates	3-7
Barrier-free bathroom design	3-7
Fire protection	3-8
Installation	3-9
Build-up and gradient	3-9
TECEdrainpoint S - the advantages	3-9
Installation examples	3-10
Range and technical data	3-11
Drain sets	3-11
Modular system	3-14
Drains	3-15
Fire protection set	3-17
Drain tops	3-17
Accessories	3-20
Assembly instructions	3-23
Installing the drain with thin-bed sealing	3-23
Installing the drain with compression flange sealing	3-26
Installing the drain without flange	3-30
Installing the “frameless” tile base	3-31
Installing the tileable channel “plate”	3-32

Introduction

Introduction

The standard for point drainage:

Innovation with a system – resistant, robust, universal.

TECE is offering a completely newly developed and innovative drain range made of plastic.



Planning

Sealing

Building components and structures are constantly exposed to moisture. Indoors, it is mainly “wet and moist rooms” that are affected: bathrooms, washrooms and kitchens in the private sector, large kitchens, washing facilities and production rooms in the commercial and industrial sectors as well as swimming pools, sports facilities and shower facilities in the public sector. Moisture can penetrate the building components and cause changes in the building's physics or chemistry, for example deterioration of the thermal insulation or mould growth. This can lead to the destruction of building components and to adverse health effects for the occupants.

To protect building components and structures from moisture and humidity, the local requirements, guidelines, standards and laws must be observed.

Connection of composite seals to floor drains, shower channels and profiles

Floor drains, shower channels and profiles are penetrations of the surface sealing (composite seal). Special attention is required here to ensure that these particular points remain permanently watertight. Planners must coordinate the plumber, screed layer and tiler trades. This includes realistically determining the water impact classes, selecting the appropriate materials and products for substrates, the composite seal and drains or channels. The construction work must then be carried out professionally.

Seal System – Tested composite seal



The Seal System project was launched to change the confusing and uncertain situation of connecting composite seals to floor drains and shower channels.

First the Seal System sealing tape was developed, followed by the Seal System sealing sleeve. They are the connecting elements between composite seal and drainage solution (channel/floor drain).

Very extensive combination tests were then carried out on composite sealing products with the TECEdrainline shower channels, the TECEdrainprofile shower profile and TECEdrainpoint S floor drains. The functional reliability (tightness) of the connection of the composite seal to the TECE drainage products was tested. The tests were carried out by the independent testing institute KIWA TBU in accordance with the testing principles (PG-AIV-F/-B) for composite seals applicable in Germany.

Numerous composite sealing products from renowned manufacturers have been successfully tested.

The tested safety can be recognised by the Seal System quality seal. "Seal System - Tested Composite Seal" thus stands for tightness of the connection between drainage solution and composite seal and for a test certificate that provides planners, applicators and end users with security and an overview.

The currently tested composite seal products are listed in the table on the following page.

Seal System is available for the TECEdrainline shower channels, the TECEdrainprofile shower profile and the TECEdrainpoint S plastic drain range. You can find information on the components and structure of the other TECE products in the corresponding sections.

The TECEdrainpoint S Seal System consists of the following components:

- TECEdrainpoint S floor drain with universal flange
- Seal System sealing sleeve
- One of the tested sealing products

Planning

Example of a Seal System seal for a TECEdrainpoint S drain with a tested sealing product:

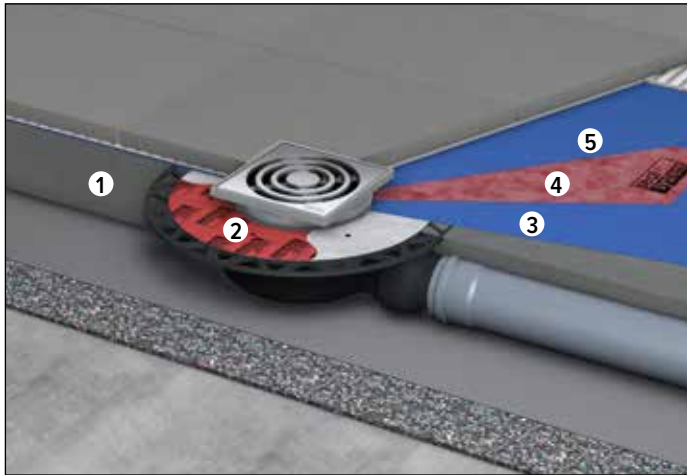

- 1 Screed
- 2 Universal flange protective foil
- 3 First coat of composite seal
- 4 Seal System sealing sleeve
- 5 Second coat of composite seal

A test certificate is available for each composite sealing product that has passed the test (www.tece.com/en/drainage/seal-system).



Seal System test certificate (example)

The shower profiles, shower channels and floor drains are identified with the Seal System imprint on the sealing sleeves and the product packaging. Each of the products is accompanied by a brief explanation of Seal System and a list of all tested composite sealing products. This makes it easy for the installer on the construction site to select a safe and tested composite sealing product.

At www.tece.com/en/drainage/seal-system you can find all test certificates of the successfully tested composite sealing products and information on Seal System.

Manufacturer	Seal System tested product
Ardex	Ardex 8 + 9
	Ardex S1 K
	Ardex SK 100 W
Botament	Botament Botact DF 9
Otto Chemie	Ottoflex slurry seals
	Ottoflex liquid membrane
Kemper	Kemperol 022
Kiesel	Okamul DF
	Servoflex DMS 1K - Fast Super Tec
	Servoflex DMS 1K
Mapei	Mapegum WPS
	Mapelastic
	Monolastic Ultra
PCI	Ceresit CL 50
	Ceresit CL 51
	Ceresit CR 72
	PCI Lastogum
	PCI Pecilastic W
	PCI Seccoral 1K
Ramsauer	1220 Flex membrane
	1240 Flex slurry seal
	1280 Flex 2K slurry seal
Rywa	Rywalit DS 01 X
	Rywalit DS 99 X
	Rywalit Lastodicht
Saint Gobain Weber	weber.tec 822
	weber.tec 824
	weber.tec Superflex D2
Sakret	Sakret FDS flexible slurry seal
Schomburg	Aquafin 1K Flex
	Aquafin 2K
	Aquafin 2K/M
	Aquafin RS300
	Saniflex

Manufacturer	Seal System tested product
Sika	Schönox HA
	Schönox 1K DS
	Schönox 2K DS Rapid
Sopro	Sopro AEB 640
	Sopro DSF 423
	Sopro DSF 523
	Sopro DSF 623
	Sopro FDF
	Sopro TDS 823

Seal System tested composite seal products

Drains

The technical requirements for drains for buildings are regulated in DIN EN 1253. The standard specifies, among other things, the minimum drain capacities, the sealing water heights of odour traps and the load-bearing capacity of grates.

Drainage capacities and odour traps

The minimum discharge values for drains with one or more inlets are specified in section 4.8.1 of DIN EN 1253-1 as follows:

Nominal value of the drain nozzle		Floor drains	
DN / OD	DN / ID	Minimum discharge values	Water storage level a
32	30	0.4 l/s	20 mm
40	40	0.6 l/s	20 mm
50	50	0.8 l/s	20 mm
75	70	0.8 l/s	20 mm
110	100	1.4 l/s	20 mm

Drainage capacity (inflow over the grate) - Minimum drainage values for drains

Odour traps are designed to prevent sewer gases from entering the building. DIN EN 1253 therefore requires odour traps to have a minimum sealing water height of 50 mm. In certain cases, an odour trap is not absolutely necessary in outdoor areas.

Load-bearing capacity of grates

Drains, attachments and grates must be designed to withstand the expected loads (for example, including vehicular traffic). These classifications for installation inside buildings are described in DIN EN 1253-1.

Load class	Test load	Area/location of use
H 1.5	150 kg (1.5 kN)	Surfaces on which no load is expected.
K 3	300 kg (3 kN)	Surfaces without vehicle traffic, such as flats, commercial and some public buildings. Such as bathrooms in flats, hotels, retirement homes, schools, swimming pools, public washing and shower facilities, balconies, loggias, terraces and green roofs.
L 15	1.5 t (15 kN)	Surfaces with light vehicle traffic, such as in commercially used premises and public areas.

Load classes of gratings according to DIN EN 1253-1

It is the responsibility of the planner to select the appropriate class. If in doubt, always select the higher load class.

Barrier-free bathroom design

Demographic changes have led to an increased demand for barrier-free homes. A disability, an accident or increasing age - there are numerous reasons why people are restricted in their ability to move or are dependent on a wheelchair.

It is important for them that public buildings but especially their own four walls are equipped in such a way that they can move around in them without difficulty. "Barrier-free" is the professional term. This requires sufficiently wide doors, no thresholds, no steps, and a shower at ground level. The TECEdrainprofile makes life without bumps and steps possible in the shower area. The floor-level shower profile makes it easier to "enter" the shower area.

When planning a barrier-free sanitary room, the local requirements, guidelines, standards and laws must be observed.

Planning

Fire protection

Fire protection solution for vertical drains DN 50/70/100

The TECE fire protection sleeves offer a safe and innovative fire protection solution up to fire resistance class EI 120 in accordance with DIN EN 13501-2:2007 and A1:2009.

Inside the fire protection sleeves are special plasterboard panels enriched with additives. Adhesive strips of intumescent material based on expanded graphite are applied in the outer and nozzle areas.

Fire protection set for vertical DN 50 drains:

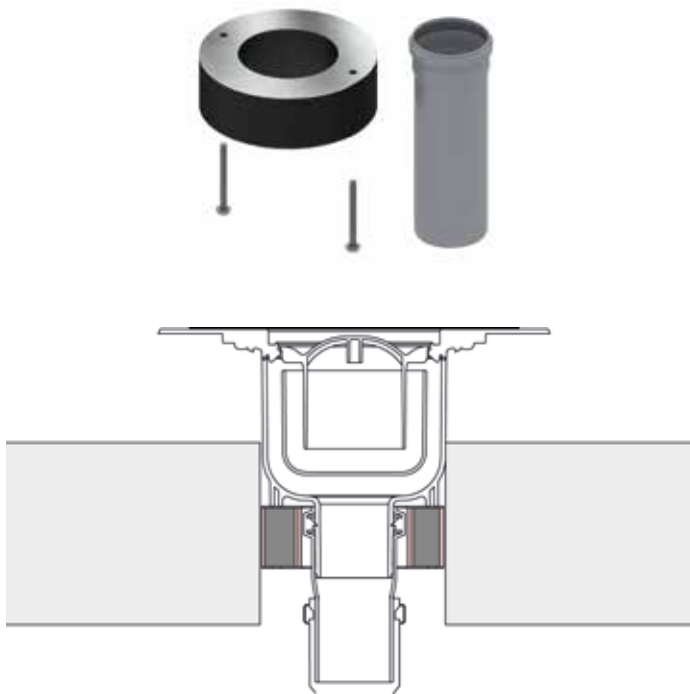

When temperatures rise in the event of a fire, this material foams up many times its original shape. In the outer area of the fire protection collar, this closes the remaining circumferential gap to the core drill hole.

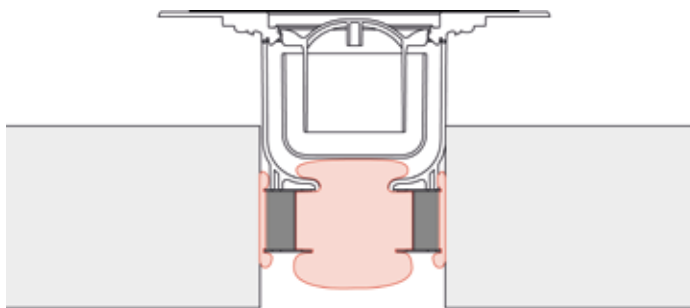

In the nozzle area, the drain nozzle including the attached PP- HT pipe socket is crushed.

Fire protection set for vertical DN 70/100 drains:

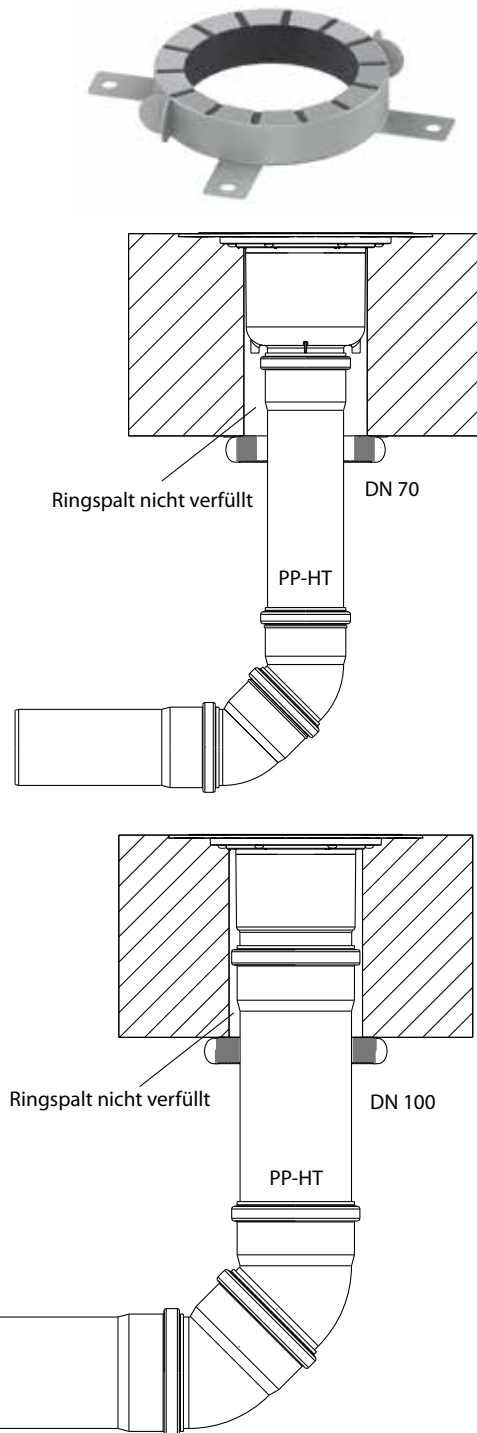

Note:

An HT pipe must be used as a connection to the drain, otherwise partitioning in the event of a fire cannot be guaranteed. 100 mm behind the fire protection collar, it is possible to change to a different pipe material.

The sealing water (siphon) in the drain ensures that no flue gas escapes into the room that is to be protected. Combined, this creates a tested, highly fire-resistant pipe closure system (or firewall). The usual mortaring/filling of the gap between the pipe or sleeve and the core drill hole is not necessary with the TECE fire protection sets.

Installation

When it comes to planning a floor drain there are various issues to consider. First of all, there is the question of the intended use: Is a drain used in the bathroom as a shower drain or as an emergency/additional drain, is it used as a basement drain or even outdoors as a terrace drain, etc. Depending on the area of application, there are of course special requirements such as sealing, fire protection requirements, protection against drying out or also protection against frost.

As well as these basic requirements, there are of course other issues relevant to planning. These can be issues such as positioning, installation heights, drainage capacity or gradients (both of the drainage pipe and of the screed or floor covering).

Build-up and gradient

The basic requirement for problem-free operation of a floor drain is, of course, the right gradient. This must always lead to the drain, regardless of the direction, and should be at least 1% (1% corresponds to 1 cm/m). This is easiest to implement if the area to be drained is relatively small and the drain is located exactly in the middle of this area. In this case, it is sufficient if an even tile cut is continued from the four corners of the drain on the surface to be drained. This central positioning can also be considered standard in bathroom drainage.

However, it becomes more problematic as soon as the positioning is decentralised or the area to be drained becomes larger and no longer corresponds to a simple geometric shape. What is possible to manage with decentralised positioning on a small area by adjusting the tile cuts is often no longer sufficient for larger areas and can only be solved by using several drains. However, it must be carefully considered which area is to be drained into which drain and that no "dead spaces" are created in which the water stagnates.

TECEdrainpoint S - the advantages

The universal flange

Just a single flange for all applications - this allows both liquid and sheet composite seals as well as compression flange connections.

The advantage: No more differentiation in planning and ordering.

Direct thin-bed sealing without drain top

With the universal flange of the new TECEdrainpoint S drains, DN 50 - and now also DN 70 and DN 100 drains - can be installed directly in the thin-bed sealing without an additional raising element.

Universality

Whether it's DN 50 super flat or DN 100 vertical, there is only one size for all drain tops, raising elements and grating frames. Grates with dimensions 100 x 100 mm and 150 x 150 mm also fit all drains.

Always the right drain

Whether only a low installation height is available or a high drainage capacity is required, you can always find the right drain in the TECEdrainpoint S range. For example, the TECEdrainpoint S DN 70 with 98 mm installation height is one of the flattest DN 70 floor drains on the market.

Innovation

The removable, two-stage membrane odour trap reliably prevents unpleasant odours from escaping.

Cleaning and maintenance

All odour traps can be removed at any time, even after installation.

Installation examples

Installation examples

The TECEdrainpoint S plastic drains combine several application options in a single drain system. They can be used as bathroom, floor, terrace or basement drains.

Appropriate drain bodies, drain tops and accessories are available for each of these situations.

Shower drain

A shower drain is usually installed in the screed. For this, it is fixed to the unfinished floor, connected to the drain side after which the screed is laid in such a way that it completely surrounds the drain. When the screed has dried, the floor area including the drain - for floor-level shower areas also the entire room according to DIN 18534 - must be sealed. After sealing, the tile or floor covering can be installed.

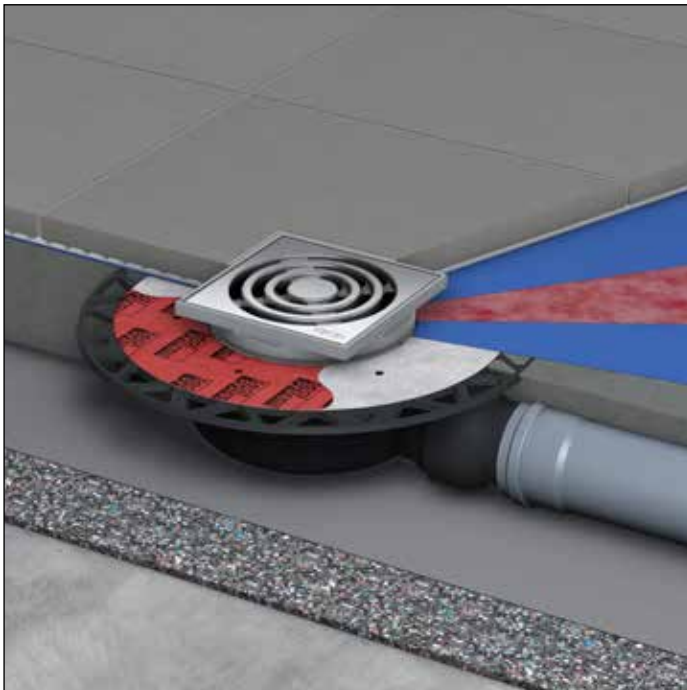

Installation in the bathroom/shower area with composite seal

Terrace drain

A floor drain that is to be used on terraces, balconies or other open areas must not have an odour trap with a sealing water barrier. Otherwise, this sealing water could freeze in the winter months, resulting in frost damage. With the TECEdrainpoint S plastic drains, it is possible to use a membrane odour trap without a cup. This then protects against any sewer gases and at the same time acts as a vermin barrier.

Installation in the basement

In most cases, a basement drain is used to remove water that does not occur on a regular or planned basis. This type of drain is therefore usually found near technical equipment, such as in laundry rooms or boiler rooms. Its purpose is to absorb water that is released by these appliances, for example in the event of damage.

Since tiles are rarely used in basements, basement drains are generally not sealed with composite seals but the basement floor below the screed.

If the basement floor is sealed, it naturally makes sense to insert the basement drain into this sealing level. For this, however, the drain must already be cast into the basement floor. The basement is then usually sealed by applying bituminous welded membranes, which are welded to the unfinished floor with a torch. To connect a TECEdrainpoint S basement drain to this type of welded membrane, the EPDM cut-to-size sealing foil is used. This is first attached to the floor drain with the press ring set. The cut-to-size sealing foil can then be worked onto the welded membrane with a hot air blower.



Installation in the basement area, sealing with compression flange sealing

Range and technical data

The TECEdrainpoint S plastic drain range has a modular design and consists of six complete drains, a drain modular system and various accessories

Drain sets

The six drain sets each consist of a drain body, a drain top and a cover. All drain sets have a drain nozzle with a nominal width of DN 50. There are five horizontal versions (3 x superflat and 2 x standard) and one vertical variant.



The six TECEdrainpoint S drain sets

Drain set S 50

Floor drain set horizontal, extra-flat, DN 50

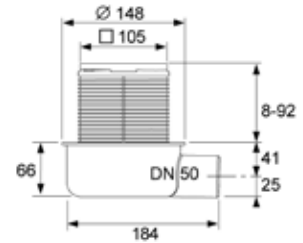
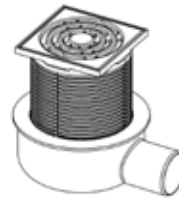

Consisting of:

- Plastic drain body DN 50 horizontal, extra-flat, (PP)
- With retaining edge
- With removable odour trap
- Reduced sealing water height = 30 mm
- Plastic drain top with grate frame (ABS) and O-ring seal
- TECEdrainpoint S design grate made of drawn stainless steel, material 1.4301 (304), dimension 100 x 100 mm polished surface, load class K3 (load of up to 300 kg)

Drainage capacity according to DIN EN 1253 at 10/20 mm water level above grate:

- With minimum height of the drain top: 0.52/0.61 l/s
 - With maximum height of the drain top: 0.69/1.12 l/s
- Item no. 3601050

Drain set S 110

Floor drain set horizontal, extra-flat, DN 50

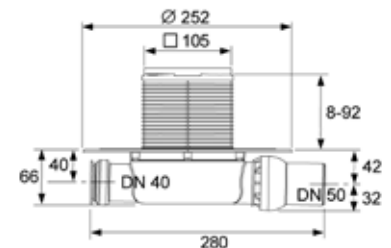
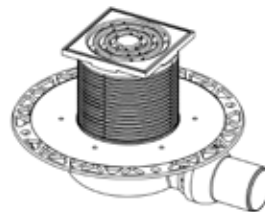

Consisting of:

- Plastic drain body DN 50 horizontal, extra-flat, (PP)
- With universal flange to connect composite seals according to DIN 18534 or compression flange connections
- With ball joint
- With lateral inflow DN 40 including closure plug
- With removable odour trap
- Reduced sealing water height = 30 mm
- Plastic drain top with grate frame (ABS) and O-ring seal
- TECEdrainpoint S design grate made of drawn stainless steel, material 1.4301 (304), dimension 100 x 100 mm polished surface, load class K3 (load of up to 300 kg)

Drainage capacity according to DIN EN 1253 at 10/20 mm water level above grate:

- With minimum height of the drain top: 0.52/0.61 l/s
 - With maximum height of the drain top: 0.69/1.12 l/s
- Item no. 3601100

Range and technical data

Drain set S 112

Floor drain set horizontal, super flat with universal flange, DN 50, stainless steel grate frame with stainless steel grate and membrane odour trap

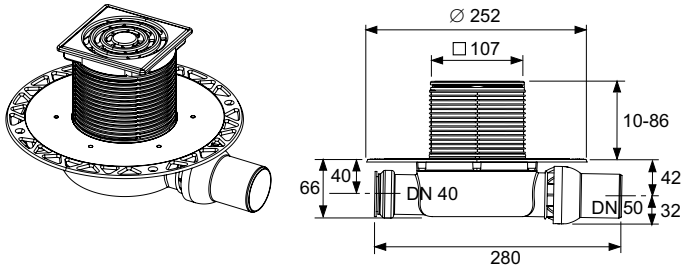

Consisting of:

- Plastic drain body DN 50 horizontal, extra-flat, (PP)
- With universal flange to connect composite seals according to DIN 18534 or compression flange connections
- With ball joint
- With lateral inflow DN 40 incl. closure plug
- With removable membrane odour trap
- Reduced sealing water height = 20 mm
- Plastic drain top (ABS) and O-ring seal
- Grate frame made of drawn stainless steel, material 1.4301 (304) for grate dimension 100 x 100 mm
- TECEdrainpoint S design grate made of drawn stainless steel, material 1.4301 (304), dimension 100 x 100 mm polished surface, load class K3 (load of up to 300 kg)

Drainage capacity according to DIN EN 1253 at 10/20 mm water level above grate:

- With minimum height of the drain top: 0.52/0.61 l/s
- With maximum height of the drain top: 0.56/1.23 l/s

Item no. 3601102

Drain set S 120

Horizontal floor drain set with universal flange DN 50, tested to DIN EN 1253

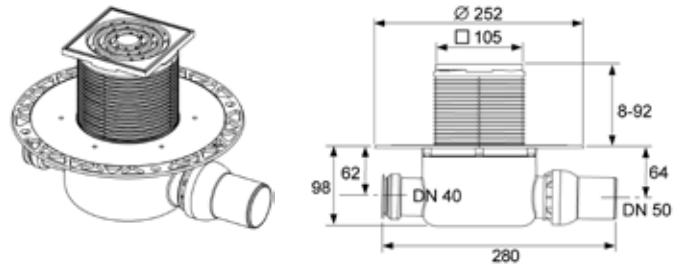

Consisting of:

- Plastic drain body DN 50 horizontal, standard, (PP)
- With universal flange to connect composite seals according to DIN 18534 or compression flange connections
- With ball joint
- With lateral inflow DN 40 incl. closure plug
- With removable odour trap
- Sealing water height = 50 mm in acc. with standard DIN EN 1253
- Plastic drain top with grate frame (ABS) and O-ring seal
- TECEdrainpoint S design grate made of drawn stainless steel, material 1.4301 (304), dimension 100 x 100 mm polished surface, load class K3 (load of up to 300 kg)

Drainage capacity according to DIN EN 1253 at 10/20 mm water level above grate:

- With minimum height of the drain top: 0.52/0.89 l/s
- With maximum height of the drain top: 0.64/1.35 l/s

Item no. 3601200

Drain set S 122

Floor drain set horizontal, standard with universal flange, DN 50, stainless steel grate frame with stainless steel grate and membrane odour trap, tested to DIN EN 1253

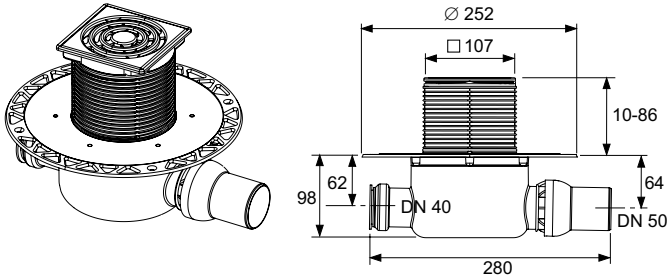

Consisting of:

- Plastic drain body DN 50 horizontal, standard, (PP)
- With universal flange to connect composite seals according to DIN 18534 or compression flange connections
- With ball joint
- With lateral inflow DN 40 incl. closure plug
- With removable membrane odour trap
- Sealing water height = 50 mm in acc. with standard DIN EN 1253
- Plastic drain top (ABS) and O-ring seal
- Grate frame made of drawn stainless steel, material 1.4301 (304) for grate dimension 100 x 100 mm
- TECEdrainpoint S design grate made of drawn stainless steel, material 1.4301 (304), dimension 100 x 100 mm polished surface, load class K3 (load of up to 300 kg)

Drainage capacity according to DIN EN 1253 at 10/20 mm water level above grate:

- With minimum height of the drain top: 0.54/0.85 l/s
- With maximum height of the drain top: 0.71/1.35 l/s

Item no. 3601202

Drain set S 130

Floor drain set vertical with universal flange DN 50, tested to DIN EN 1253

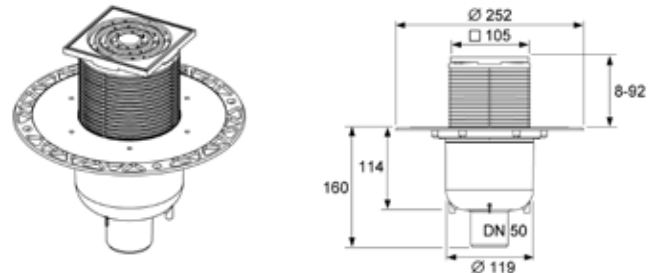

Consisting of:

- Plastic drain body DN 50, vertical, (PP)
- With universal flange to connect composite seals according to DIN 18534 or compression flange connections
- With removable odour trap
- Sealing water height = 50 mm in acc. with standard DIN EN 1253
- Plastic drain top with grate frame (ABS) and O-ring seal
- TECEdrainpoint design grate made of drawn stainless steel, material 1.4301 (304), dimension 100 x 100 mm polished surface, load class K3 (load of up to 300 kg)

Drainage capacity according to DIN EN 1253 at 10/20 mm water level above grate:

- With minimum height of the drain top: 0.64/1.36 l/s
- With maximum height of the drain top: 0.709/1.56 l/s

Item no. 3601300

Range and technical data

Modular system

Using the TECEdrainpoint modular system, a complete drain can always be produced from three basic components – drain body, drain top and cover:

- 8 drain bodies from DN 50 horizontal super flat to DN 100 vertical,
- Drain tops with grate frame made of plastic, stainless steel or tileable, □ 100 or 150 mm,
- Stainless steel design grates, 100 x 100 mm or 142 x 142 mm, “loose” or screwable.

The free combination reduces the expense of storage and simplifies ordering.

Alternatively, the six complete drain sets are available for the most common drain combinations.

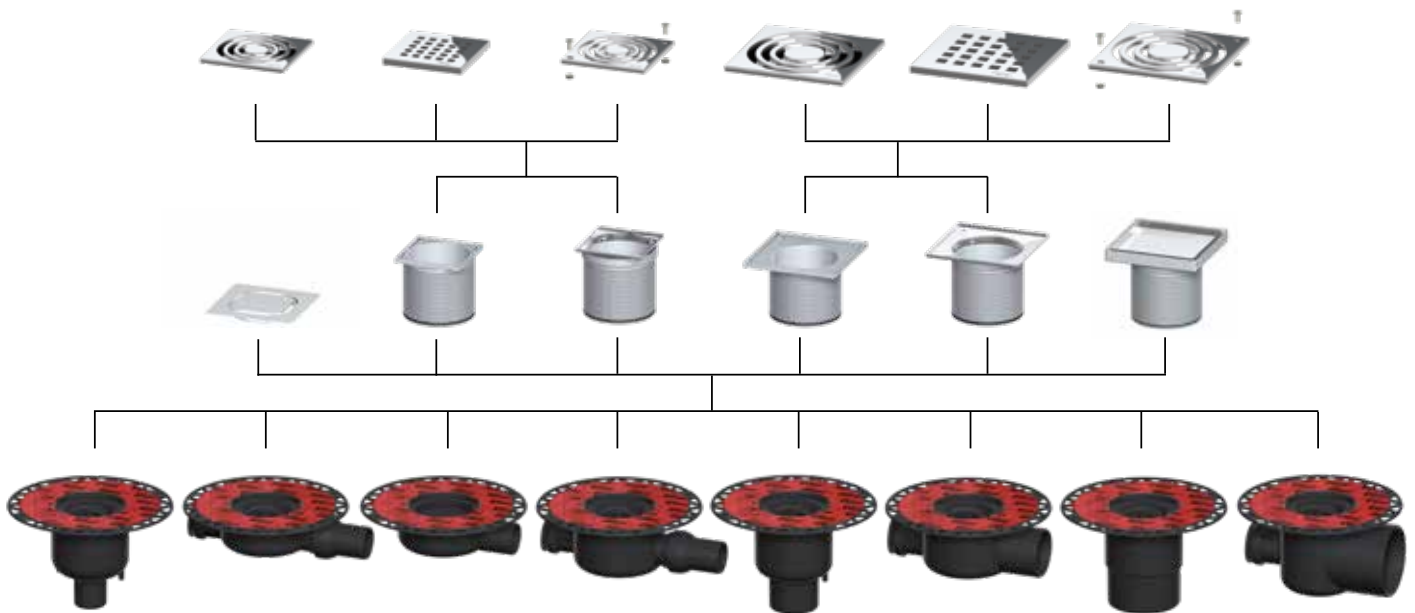

TECEdrainpoint S - the modular system

The following components are optionally available:

- Raising element with universal flange
- Extension



Drains

Drain DN 50 extra-flat

Plastic floor drain DN 50 horizontal extra-flat (PP)

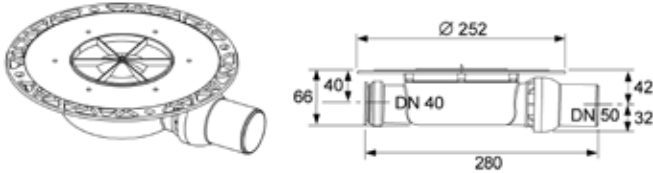

- With universal flange to connect composite seals according to DIN 18534 or compression flange connections
- With ball joint
- With lateral inflow DN 40 incl. closure plug
- With removable odour trap
- Reduced sealing water height = 30 mm

Drainage capacity according to DIN EN 1253 at 10/20 mm water level above grate:

- With minimum height of the drain top: 0.52/0.61 l/s
- With maximum height of the drain top: 0.69/1.12 l/s

Item no. 3601400

Drain DN 50 terrace super flat

Plastic floor drain DN 50 as terrace or balcony drain, horizontal extra-flat (PP)

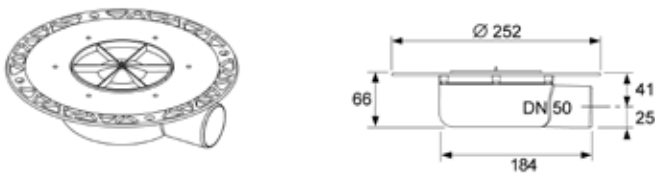

- With universal flange to connect composite seals according to DIN 18534 or compression flange connections
- Without odour trap

Drainage capacity according to DIN EN 1253 at 10/20 mm water level above grate:

- With minimum height of the drain top: 0.66/1.22 l/s
- With maximum height of the drain top: 0.50/1.51 l/s

Item no. 360 14 01

Drain DN 50 standard

Plastic floor drain DN 50 horizontal standard (PP) , tested to DIN EN 1253

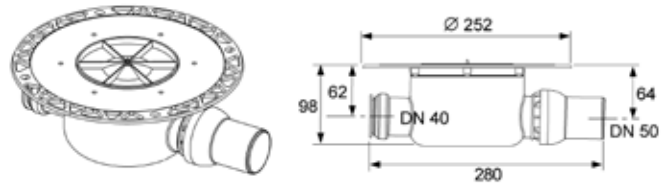

- With universal flange to connect composite seals according to DIN 18534 or compression flange connections
- With ball joint
- With lateral inflow DN 40 incl. closure plug
- With removable odour trap
- Sealing water height = 50 mm in acc. with standard DIN EN 1253

Drainage capacity according to DIN EN 1253 at 10/20 mm water level above grate:

- With minimum height of the drain top: 0.52/0.89 l/s
- With maximum height of the drain top: 0.64/1.35 l/s

Item no. 3601500

Drain DN 50 vertical

Plastic floor drain DN 50 vertical (PP), tested to DIN EN 1253

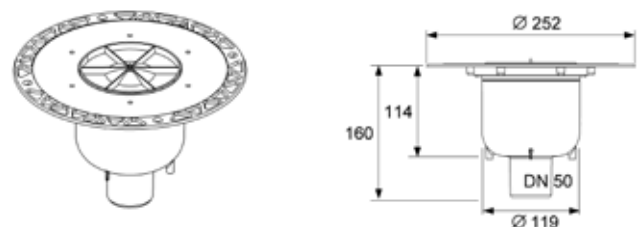

- With universal flange to connect composite seals according to DIN 18534 or compression flange connections
- With removable odour trap
- Sealing water height = 50 mm in acc. with standard DIN EN 1253

Drainage capacity according to DIN EN 1253 at 10/20 mm water level above grate:

- With minimum height of the drain top: 0.64/1.36 l/s
- With maximum height of the drain top: 0.70/1.56 l/s

Item no. 3601600

Range and technical data

Drain DN 70

Plastic floor drain DN 70 horizontal, standard (PP), tested to DIN EN 1253

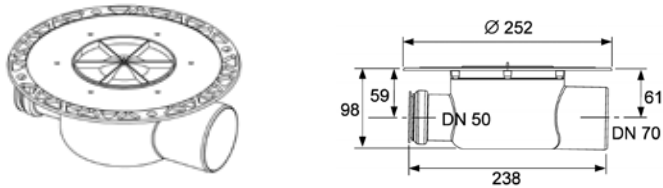

- With universal flange to connect composite seals according to DIN 18534 or compression flange connections
- With lateral inflow DN 50 incl. closure plug
- With removable odour trap
- Sealing water height = 50 mm in acc. with standard DIN EN 1253

Drainage capacity according to DIN EN 1253 at 10/20 mm water level above grate:

- With minimum height of the drain top: 0.62/1.22 l/s
- With maximum height of the drain top: 0.87/1.74 l/s

Item no. 3603500

Drain DN 70 vertical

Plastic floor drain DN 70 vertical (PP), tested to DIN EN 1253

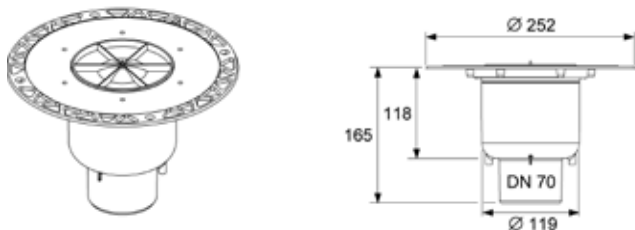

- With universal flange to connect composite seals according to DIN 18534 or compression flange connections
- With removable odour trap
- Sealing water height = 50 mm in acc. with standard DIN EN 1253

Drainage capacity according to DIN EN 1253 at 10/20 mm water level above grate:

- With minimum height of the drain top: 0.47/1.81 l/s
- With maximum height of the drain top: 0.63/1.84 l/s

Item no. 3603600

Drain DN 100

Plastic floor drain DN 100 horizontal, standard (PP), tested to DIN EN 1253

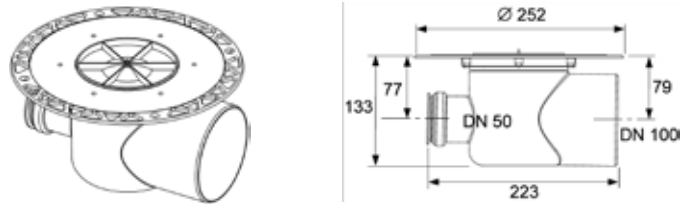

- With universal flange to connect composite seals according to DIN 18534 or compression flange connections
- With lateral inflow DN 50 incl. closure plug
- With removable odour trap
- Sealing water height = 50 mm in acc. with standard DIN EN 1253

Drainage capacity according to DIN EN 1253 at 10/20 mm water level above grate:

- With minimum height of the drain top: 0.90/1.61 l/s
- With maximum height of the drain top: 0.86/2.03 l/s

Item no. 3607500

Drain DN 100 vertical

Plastic floor drain DN 100 vertical (PP), tested to DIN EN 1253

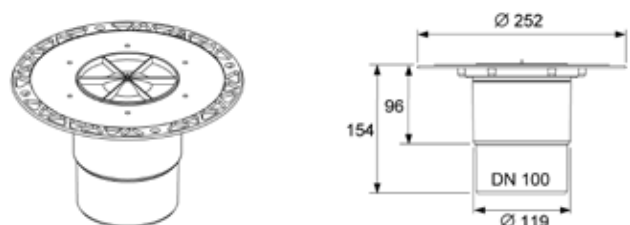

- With universal flange to connect composite seals according to DIN 18534 or compression flange connections
- With removable odour trap
- Sealing water height = 50 mm in acc. with standard DIN EN 1253

Drainage capacity according to DIN EN 1253 at 10/20 mm water level above grate:

- With minimum height of the drain top: 0.76/1.42 l/s
- With maximum height of the drain top: 0.80/2.10 l/s

Item no. 3607600

Fire protection set

Fire protection set FireStop EI 120 DN 50

Fire protection set for direct installation at the TECEdrainpoint S DN 50 drain vertical for highly fire resistant partitioning of ceiling bushings in solid ceilings for up to 120 minutes. Classification in accordance with DIN EN 13501 for fire protection class EI 120-U/C, European technical approval (ETA-11/0437).



Set consists of fire protection sleeve, 2 Philips screws, identification plate and 150 mm PP 50 PP-DN pipe to DIN EN 1451.

Required core drill hole:

Diameter 120 mm (min = 119 mm, max = 123 mm)

Application area:

Solid ceilings from 150 mm to 325 mm ceiling thickness

Grouting or filling of the gap is not necessary.

Item no. 3690050

Fire protection sleeve DN 70/DN 100

Fire protection sleeve for assembly under the ceiling, using vertical TECEdrainpoint S floor drains DN 70 and DN 100 together with a PP-HT drain pipe in accordance with EN 1451. For highly fire resistant partitioning of the ceiling bushing in solid ceilings for up to 120 minutes. Classification in accordance with DIN EN 13501 for fire protection class EI 120-U/U, European technical approval (ETA-18/0537).

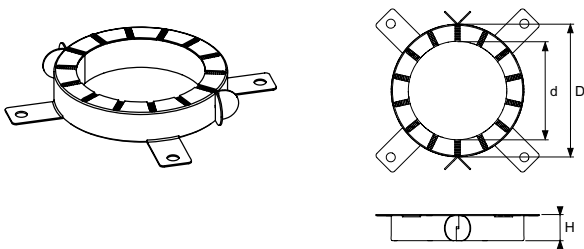

Required core drill hole:

DN 70: Diameter 122 mm

DN 100: Diameter 132 mm

Application area:

Solid ceilings \geq 200 mm thick

Grouting or filling of the gap is not necessary.

Item no. 3690070 (DN 70) /3690070 (DN 100)

Drain tops

TECEdrainpoint S grate frame stainless steel, 100 mm, "frameless tile base"

Set consisting of tileable drain top and frameless tile base, 100 x 100 mm made of stainless steel.

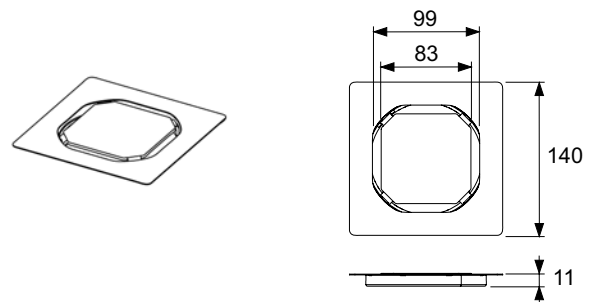

- Outer diameter = 110 mm
 - Height 1 mm (suitable for all tile/natural stone thicknesses)
 - Grate frame made of drawn stainless steel, material 1.4301 (304)
 - Stainless steel frameless tile base, material 1.4301 (304), dimensions 82 x 82 mm, polished surface, load class K3 (load of up to 300 kg)
- Item no. 3660016

TECEdrainpoint S stainless steel grate frame, 150 mm, "plate" design

Drain top set with grate frame (stainless steel) and "plate" tileable channel 142 x 142 mm

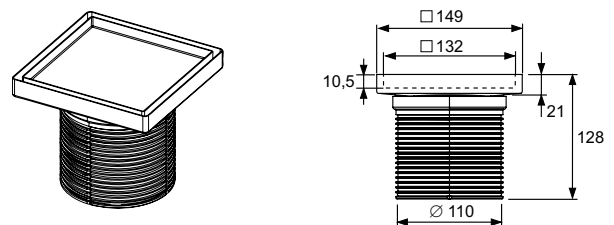

- Plastic drain top (ABS)
 - O-ring seal
 - Outer diameter = 110 mm
 - Height adjustment = 23 to 118 mm
 - Height of tileable insert = 10.5 mm
 - Grate frame made of drawn stainless steel, material 1.4301 (304)
 - Plate stainless steel tileable channel, material 1.4301 (304), dimension 142 x 142 mm, polished surface, load class K3 (load of up to 300 kg)
- Item no. 3660011

Range and technical data

TECEdrainpoint S grate frame plastic, 100 mm, incl. design grate

Drain top set with grate frame (plastic) and TECEdrainpoint design grate 100 x 100 mm

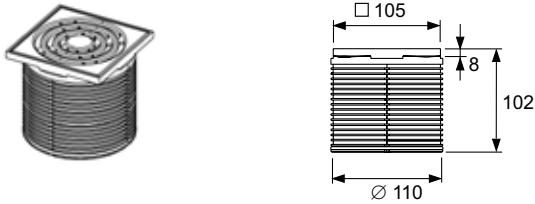

- Plastic drain top with grate frame (ABS)
- O-ring seal
- Outer diameter = 110 mm
- Height adjustment = 10 to 92 mm
- TECEdrainpoint design grate made of drawn stainless steel, material 1.4301 (304), dimension 100 x 100 mm polished surface, load class K3 (load up to 300 kg)

Item no. 3660001

TECEdrainpoint S grate frame stainless steel, 100 mm, incl. design grate

Drain top set with grate frame (stainless steel) and TECEdrainpoint design grate 100 x 100 mm

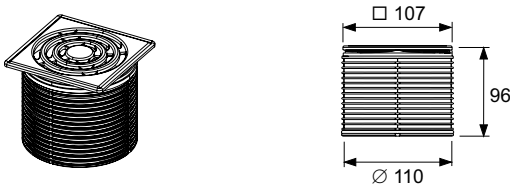

- Plastic drain top (ABS)
- O-ring seal
- Outer diameter = 110 mm
- Height adjustment = 10 to 86 mm
- Grate frame made of drawn stainless steel, material 1.4301 (304)
- TECEdrainpoint design grate made of drawn stainless steel, material 1.4301 (304), dimension 100 x 100 mm polished surface, load class K3 (load up to 300 kg)

Item no. 3660002

TECEdrainpoint S grate frame stainless steel, 100 mm, incl. design grate, screwable

Drain top set consisting of drain top with grate frame (stainless steel) and TECEdrainpoint S design grate 100 x 100 mm

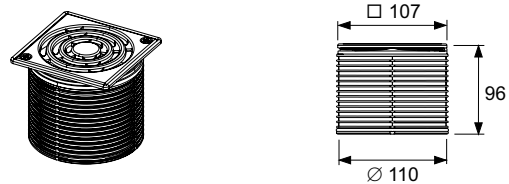

- Plastic drain top (ABS)
- O-ring seal
- Outer diameter = 110 mm
- Height adjustment = 10 to 86 mm
- Grate frame made of drawn stainless steel, material 1.4301 (304)
- TECEdrainpoint design grate made of drawn stainless steel, material 1.4301 (304), dimension 100 x 100 mm polished surface, load class K3 (load up to 300 kg)
- 2 stainless steel countersunk screws

Item no. 3660009

TECEdrainpoint S grate frame plastic, 150 mm, incl. design grate

Drain top set with grate frame (plastic) and TECEdrainpoint design grate 142 x 142 mm



- Plastic drain top with grate frame (ABS)
- O-ring seal
- Outer diameter = 110 mm
- Height adjustment = 12 to 92 mm
- TECEdrainpoint design grate made of drawn stainless steel, material 1.4301 (304), dimension 142 x 142 mm polished surface, load class K3 (load up to 300 kg)

Item no. 3660003

TECEDrainpoint S grate frame stainless steel, 150 mm, incl. design grate

Drain top set with grate frame (stainless steel) and TECEDrainpoint design grate 142 x 142 mm

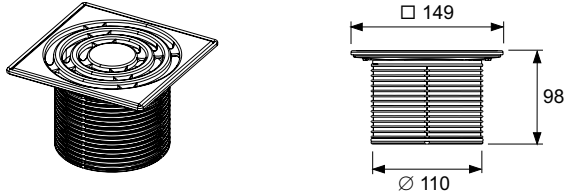

- Plastic drain top (ABS)
 - O-ring seal
 - Outer diameter = 110 mm
 - Height adjustment = 12 to 88 mm
 - Grate frame made of drawn stainless steel, material 1.4301 (304)
 - TECEDrainpoint design grate made of drawn stainless steel, material 1.4301 (304), dimension 142 x 142 mm polished surface, load class K3 (load up to 300 kg)
- Item no. 3660004

TECEDrainpoint S grate frame stainless steel, 150 mm, incl. design grate, screwable

Drain top set consisting of drain top with grate frame (stainless steel) and TECEDrainpoint S design grate 142 x 142 mm

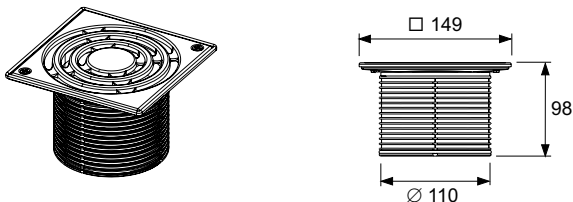

- Plastic drain top (ABS)
 - O-ring seal
 - Outer diameter = 110 mm
 - Height adjustment = 12 to 88 mm
 - Grate frame made of drawn stainless steel, material 1.4301 (304)
 - TECEDrainpoint design grate made of drawn stainless steel, material 1.4301 (304), dimension 142 x 142 mm polished surface, load class K3 (load up to 300 kg)
 - 2 stainless steel countersunk screws
- Item no. 3660010

TECEDrainpoint S grate frame stainless steel, 100 mm, incl. "quadratum" design grate

Drain top set with stainless steel grate frame and "quadratum" design grate 100 x 100 mm

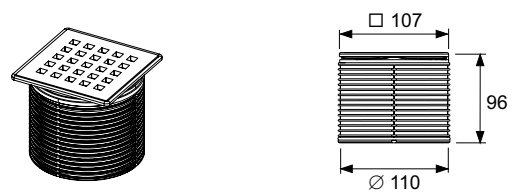

- Plastic drain top (ABS)
 - O-ring seal
 - Outer diameter = 110 mm
 - Height adjustment = 10 to 86 mm
 - Grate frame made of drawn stainless steel, material 1.4301 (304)
 - "quadratum" stainless steel design grate, material 1.4301 (304), dimension 100 x 100 mm polished surface, load class L15 (load to 1500 kg)
 - Slip resistance rating group B for wet barefoot areas according to DIN 51097
- Item no. 3660007

TECEDrainpoint S grate frame stainless steel, 150 mm, incl. design grate

Drain top set with stainless steel grate frame and "quadratum" design grate 142 x 142 mm

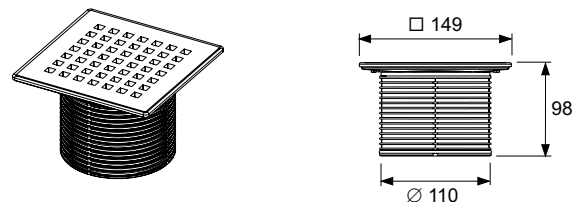

- Consisting of:
- Plastic drain top (ABS)
 - O-ring seal
 - Outer diameter = 110 mm
 - Height adjustment = 12 to 88 mm
 - Grate frame made of drawn stainless steel, material 1.4301 (304)
 - "quadratum" stainless steel design grate, material 1.4301 (304), dimension 142 x 142 mm polished surface, load class L15 (load to 1500 kg)
 - Slip resistance rating group B for wet barefoot areas according to DIN 51097
- Item no. 3660008

Range and technical data

Accessories

TECEDrainpoint S raising element with universal flange

Plastic drain top with universal flange made of plastic (PP) for composite seals and compression flange sealings

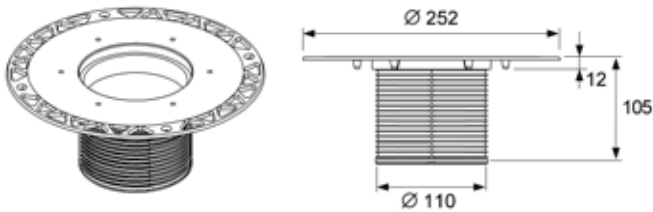

- With universal flange to connect composite seals according to DIN 18534 or compression flange connections
 - Incl. O-ring seal
 - Outer diameter = 110 mm
 - Height adjustment = 12 to 95 mm
- Item no. 3660005

TECEDrainpoint S extension

Plastic drain top extension (ABS)



- With O-ring seal
 - Outer diameter = 110 mm
 - Height adjustment = 14 to 95 mm
- Item no. 3660006

Plastic TECEDrainpoint S grate frame, 100 mm, without grate

Drain top with grate frame (plastic) without grate

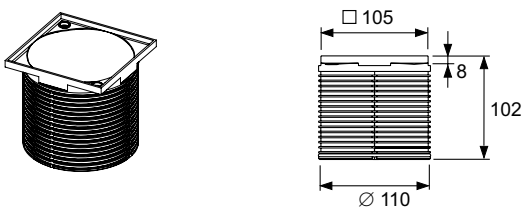

- Plastic drain top (ABS)
 - O-ring seal
 - Outer diameter = 110 mm
 - Height adjustment = 10 to 92 mm
- Item no. 3660018

Plastic TECEDrainpoint S grate frame, 150 mm, without grate

Drain top with grate frame (plastic) without grate

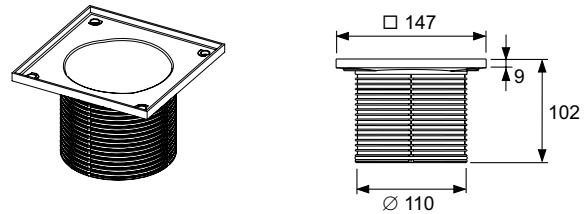

- Plastic drain top (ABS)
 - O-ring seal
 - Outer diameter = 110 mm
 - Height adjustment = 10 to 92 mm
- Item no. 3660019

TECEDrainpoint S stainless steel design grate 100 x 100 mm, screwable

TECEDrainpoint design grate 100 x 100 mm made of drawn stainless steel, material 1.4301 (304) screwable



- Dimension = 100 x 100 mm (outer dimensions)
 - Polished surface
 - Load class K3 (load to 300 kg)
 - Incl. 2 stainless steel countersunk screws and self-tapping threaded bushes
- Item no. 3665000

TECEDrainpoint S stainless steel design grate 142 x 142 mm, screwable

TECEDrainpoint design grate 142 x 142 mm made of drawn stainless steel, material 1.4301 (304) screwable

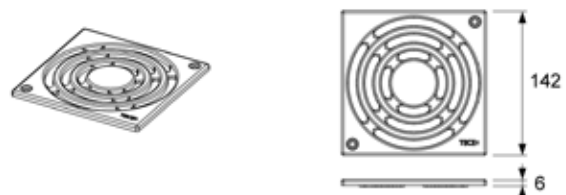

- Dimension = 142 x 142 mm (outer dimensions)
 - Polished surface
 - Load class K3 (load to 300 kg)
 - Incl. 2 stainless steel countersunk screws and self-tapping threaded bushes
- Item no. 3665001

TECEdrainpoint S stainless steel design grate 100 x 100 mm

TECEdrainpoint design grate 100 x 100 mm made of drawn stainless steel, material 1.4301 (304)



- Dimension = 100 x 100 mm (outer dimensions)
 - Polished surface
 - Load class K3 (load to 300 kg)
- Item no. 3665002

TECEdrainpoint S stainless steel design grate 142 x 142 mm

TECEdrainpoint design grate 142 x 142 mm made of drawn stainless steel, material 1.4301 (304)

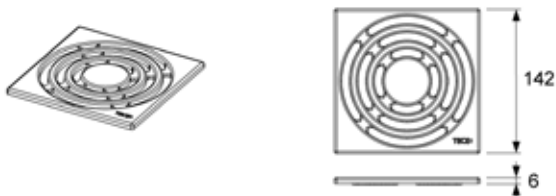

- Dimension = 142 x 142 mm (outer dimensions)
 - Polished surface
 - Load class K3 (load to 300 kg)
- Item no. 3665003

TECEdrainpoint S “quadratum” design grate 100 x 100 mm

made of stainless steel, material 1.4301 (304)



- Dimension = 100 x 100 mm (outer dimensions)
 - Polished surface
 - L15 (load to 1500 kg)
 - Slip resistance rating group B for wet barefoot areas according to DIN 51097
- Item no. 3665006

TECEdrainpoint S stainless steel “quadratum” design grate

142 x 142 mm

made of stainless steel, material 1.4301 (304)

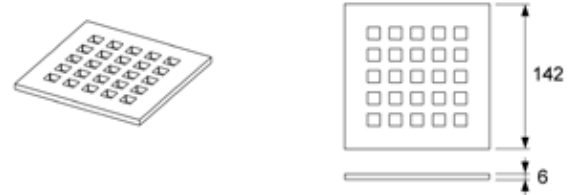

- Dimension = 142 x 142 mm (outer dimensions)
 - Polished surface
 - L15 (load to 1500 kg)
 - Slip resistance rating group B for wet barefoot areas according to DIN 51097
- Item no. 3665009

TECEdrainpoint S stainless steel compression ring, incl. screws and seal

Compression sealing ring set for compression flange connections



- Stainless steel compression ring, material 1.4301 (304) with pre-drilled hole circle
 - Sealing ring made of cellular rubber
 - 6 stainless steel screws
- Item no. 3690003

TECEdrainpoint S Seal System sealing sleeve for composite seals

Seal System sealing sleeve for tested and certified connection of TECEdrainpoint S drains to the composite seal

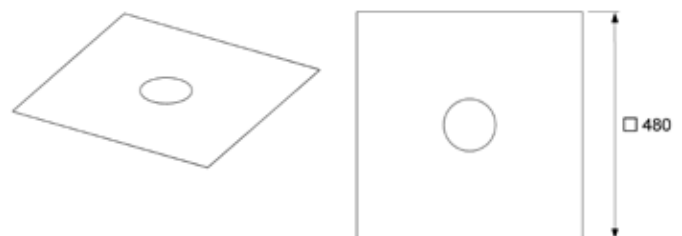

- PP fleece (top and underside) and inner waterproof PE foil
 - Dimension = 480 x 480 mm
- Item no. 3690004

Range and technical data

TECEDrainpoint S cut-to-size sealing foil EPDM

Seal sleeve for the connection of bitumen membrane sheets, polymer bitumen membrane sheets or EPDM sealing layers using hot-air welding, full-area welding or gluing with PU adhesive. The sealing sleeve is fixed on the universal flange with the compression ring set.

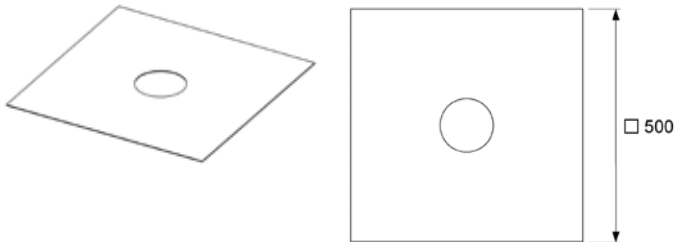

- Material: EPDM with insert of glass cloth, underside with polymer-modified bitumen coating and fine quartz coating
 - Dimension = 500 x 500 mm
 - Material thickness = 3.1 mm
 - Manufacturer: Phoenix Restrix Classic
- Item no. 3690006

TECEDrainpoint S membrane odour trap

Odour trap for TECEDrainpoint S drains made of plastic (PP) with inner sealing lip membrane as protection against evaporation, barrier against odours and vermin, sealing water and sealing lip membrane provide two-stage trap effect. For retrofitting all TECEDrainpoint S floor drains.



- Available in three versions, for DN 50 superflat drains; for DN 50 standard and vertical drains; for DN 70 and DN 100 drains
 - Two-stage odour trap
- Item nos. 3695002, 3695005, 3695006

TECEDrainpoint S hair trap

made of plastic, for insertion in the TECEDrainpoint S drain



Item no. 3690005

TECEDrainpoint S assembly feet, sound-insulated

for easy height alignment and fixation during shell installation of Drainpoint S drains with Seal System universal Flange



Adjustment range lower edge of feet to the upper edge of universal flange: 64 to 165 mm

Consisting of 4 assembly feet incl. sound-proofing element and mounting material
Item no. 3690007

Drainbase sound insulation mat

Sound insulation mat for TECEDrainline, TECEDrainprofile and TECEDrainpoint S

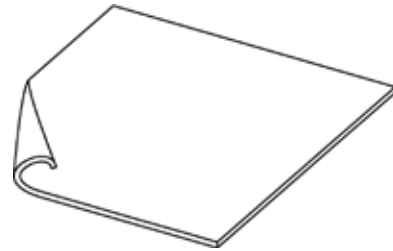

Drainbase sound insulation mat

Sound insulation mat for assembly under floating screed in the area of floor-level showers or throughout the bathroom. To reduce installation noise and impact noise insulation for renovations and new constructions. Made from recycled high-tensile rubber granules bound with PUR elastomer. Meets enhanced sound insulation requirements for installation noise level according to DIN 4109 supplement 2, issued 1989-11 and the highest sound insulation level SSt III according to VDI 4100, issued 2012-10 (sound test verification available on request).

- Delivery form: 1.25 m x 1.25 m x 6 mm and 8.0 m x 1.25 m x 6 mm (roll, approx. 50 kg)
 - Impact noise reduction: $\Delta L_w = 20$ dB(A) (with 50 mm screed)
 - Fire class: B2 (DIN 4102)
 - Thermal resistance: 0.05 (m²·K)/W
 - Compression at 15 t/m²: 0.6 mm
- Item no. 660001 or 660002

Assembly instructions

Installing the drain with thin-bed sealing

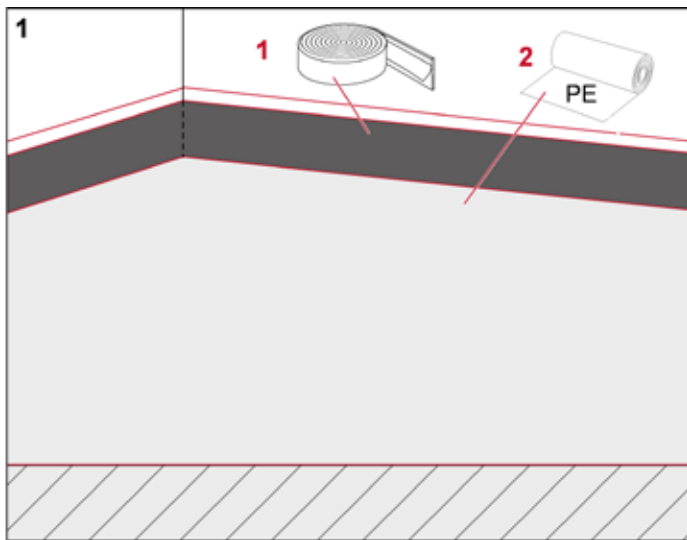

Attach edge insulation strip and lay PE foil.

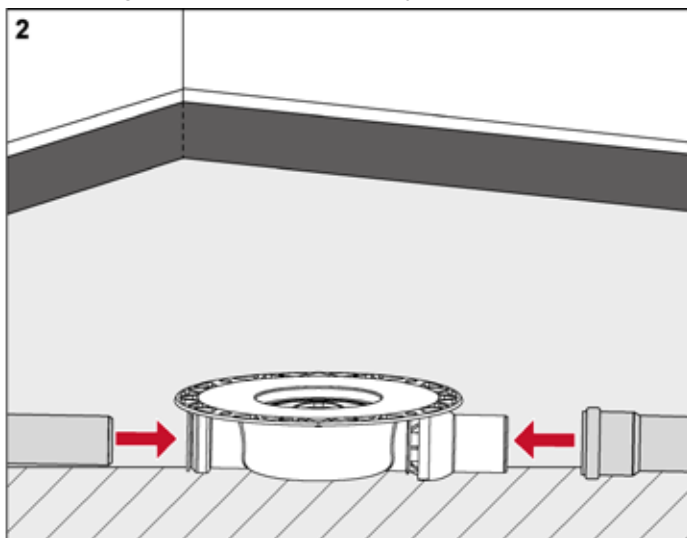

Position the drain and connect it to the waste water side. For drains with a vertical nozzle, a coring with a diameter of 130 mm is required.

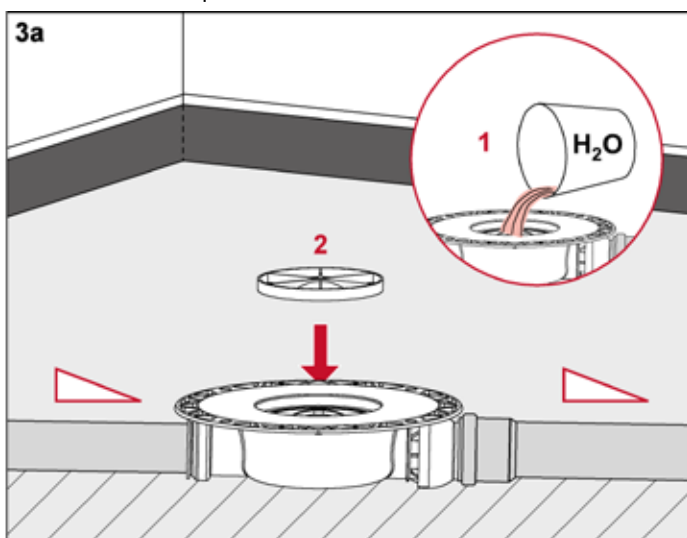

Carry out a leak test.

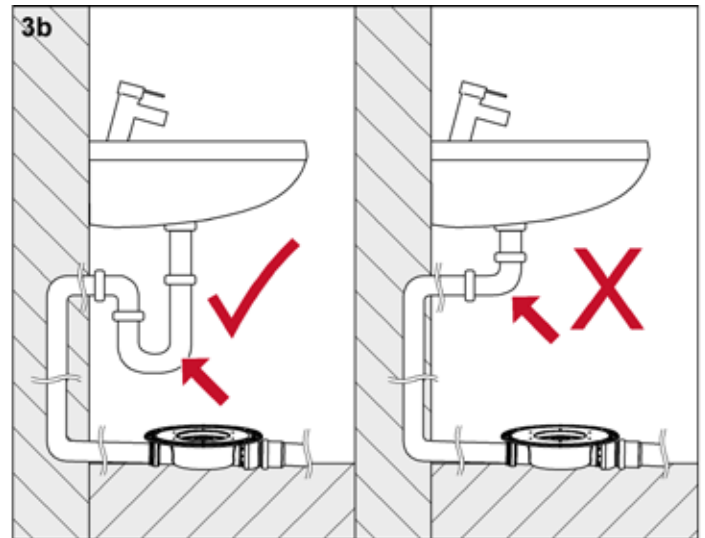

An odour trap is required in the inlet pipe when using the side inlet.

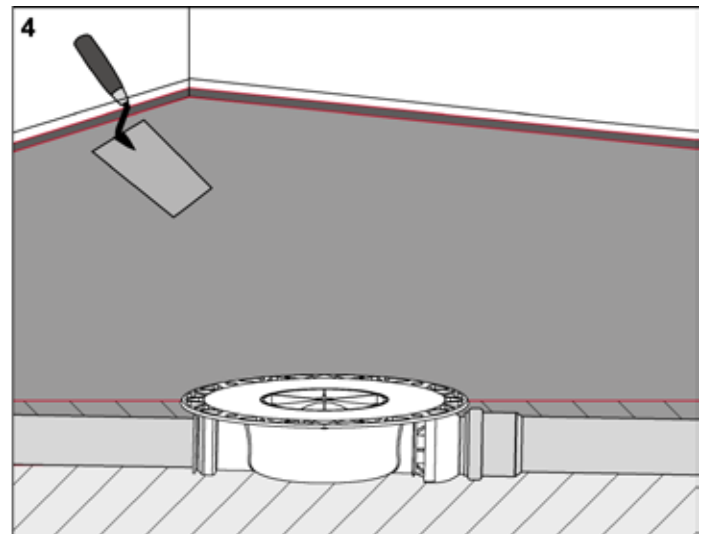

Apply the screed.

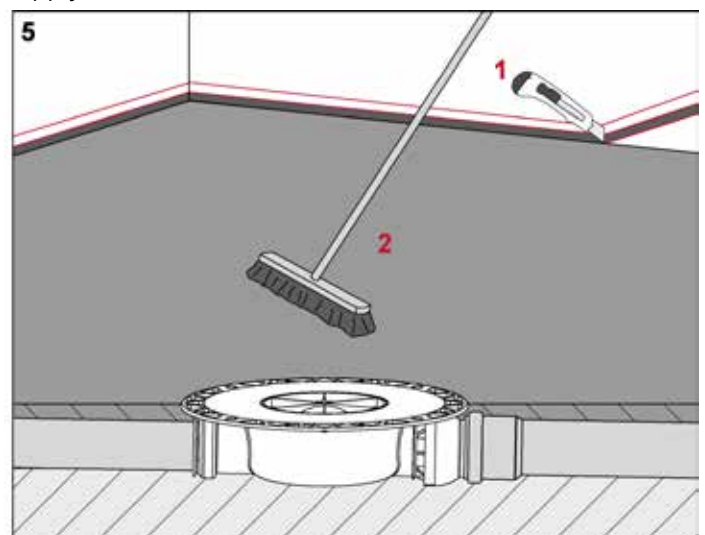

After drying, cut off the protruding edge insulation strip and PE foil, clean screed.

Assembly instructions

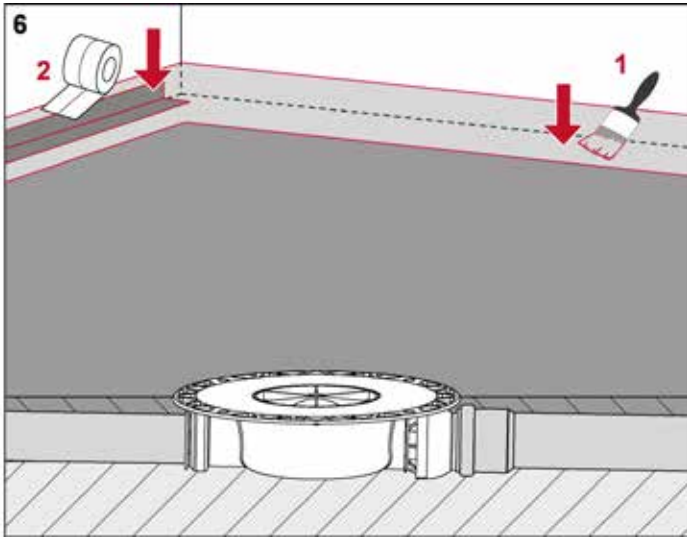

Apply sealing coat and sealing tape at the transition between the screed and the wall (if necessary also to other screed surfaces).

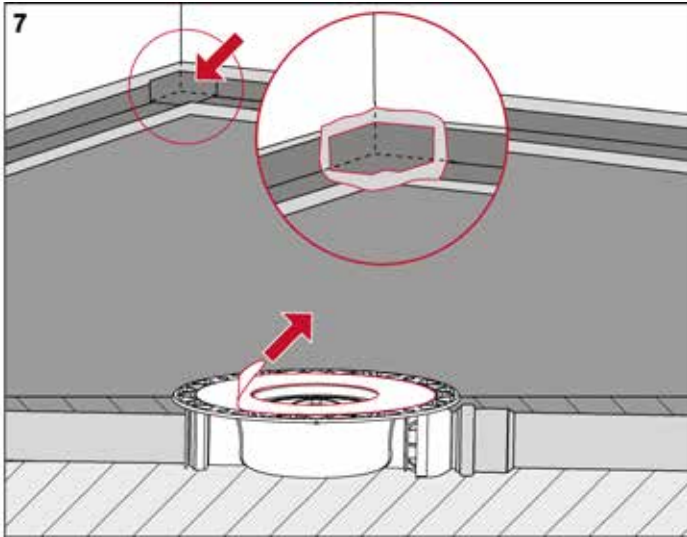

Attach the sealing corner(s), remove the protective foil from the flange.

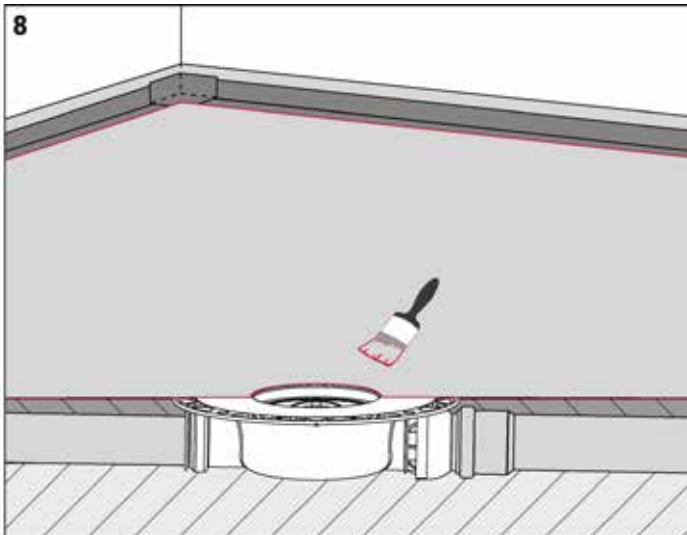

Apply the first sealing coat over the entire surface

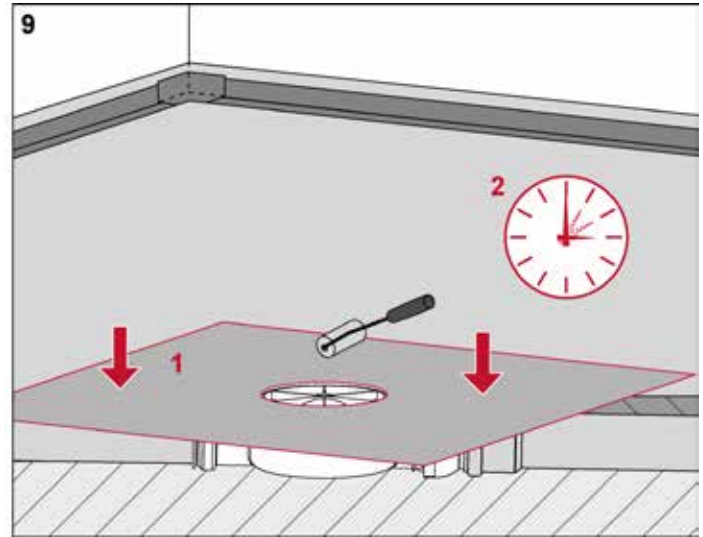

Insert the sealing sleeve into the fresh coat and press on without wrinkles. Allow the coating to dry.

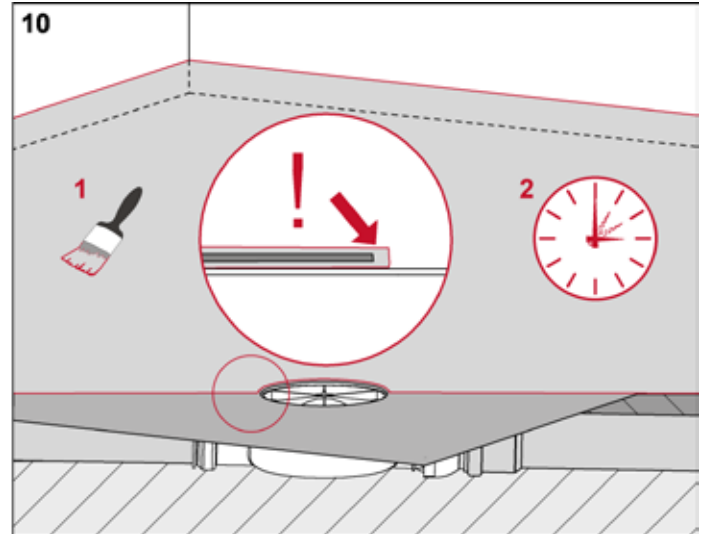

Apply the second sealing coat over the entire surface: the sealing sleeve should be completely enclosed by the sealing coat. Allow the coating to dry.

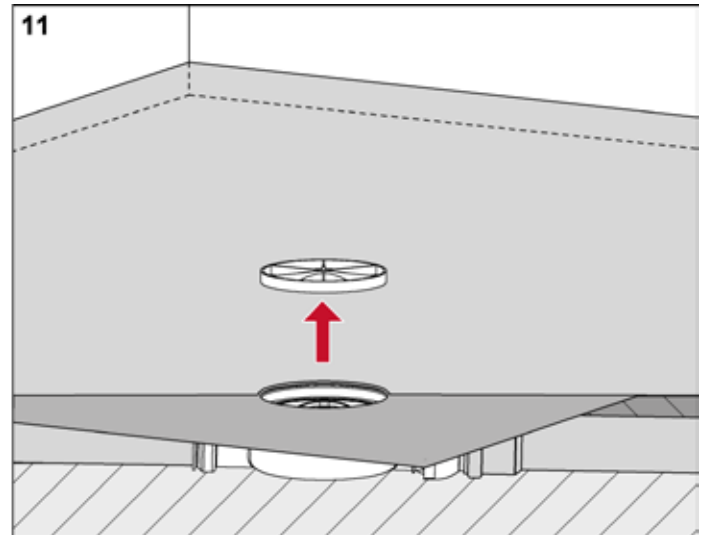

Remove the construction time protection.

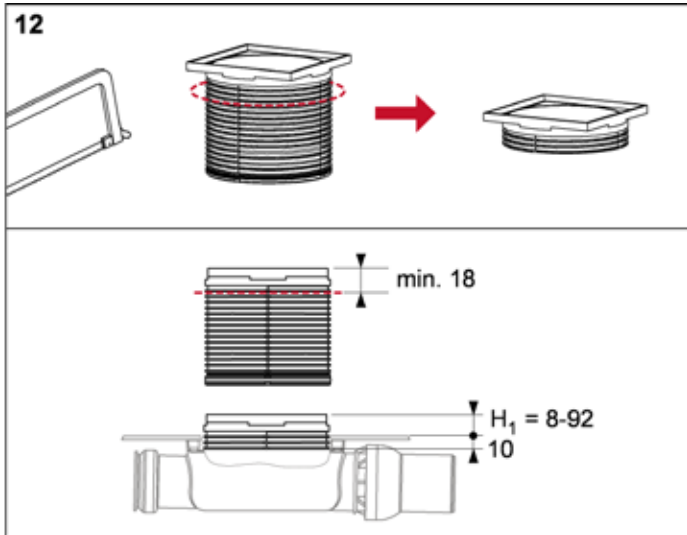

Cut the drain top to length.

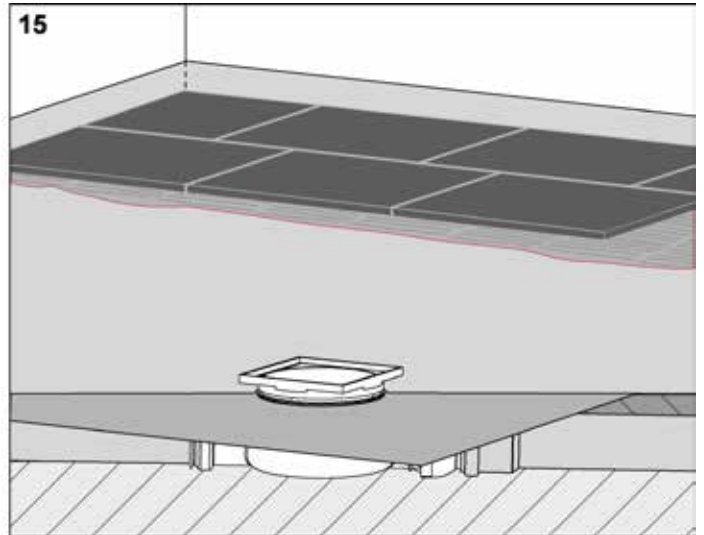

Apply the floor covering.

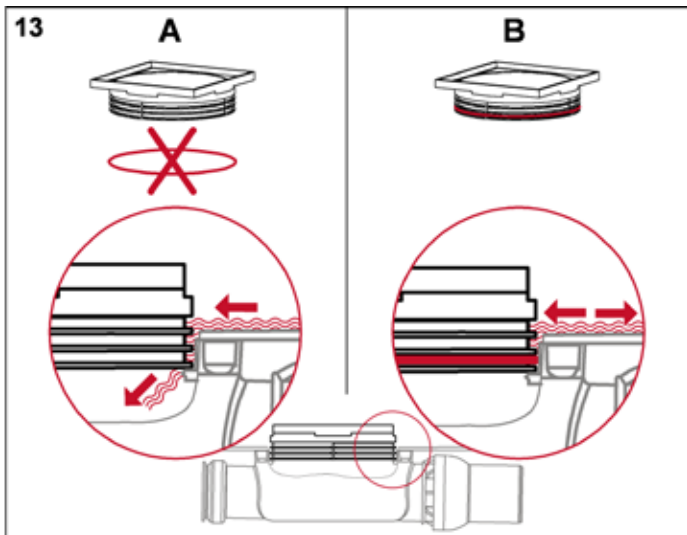

Seepage water drainage is guaranteed without an O-ring.

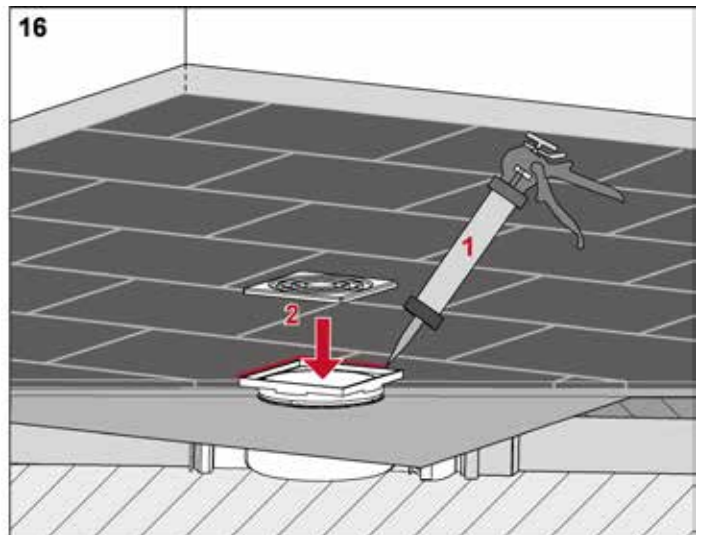

Seal the joint with permanently elastic material and insert grate.

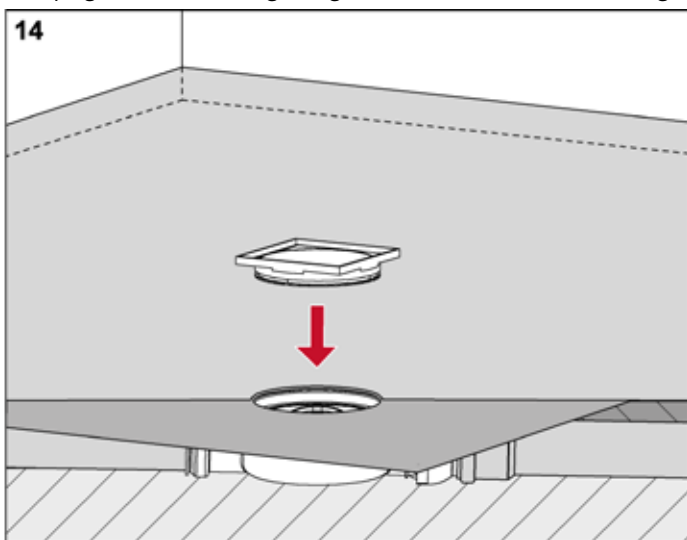

Apply the cut-to-length drain top.

Assembly instructions

Installing the drain with compression flange sealing

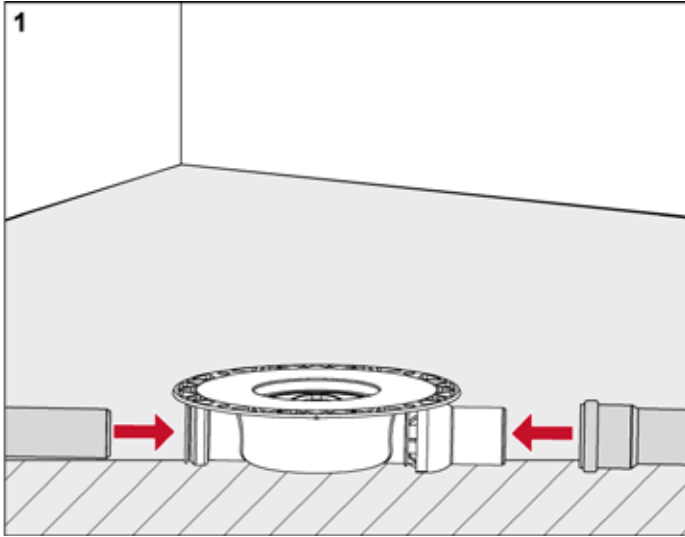

Position the drain and connect it to the waste water side. For drains with a vertical nozzle, a coring with a diameter of 130 mm is required.

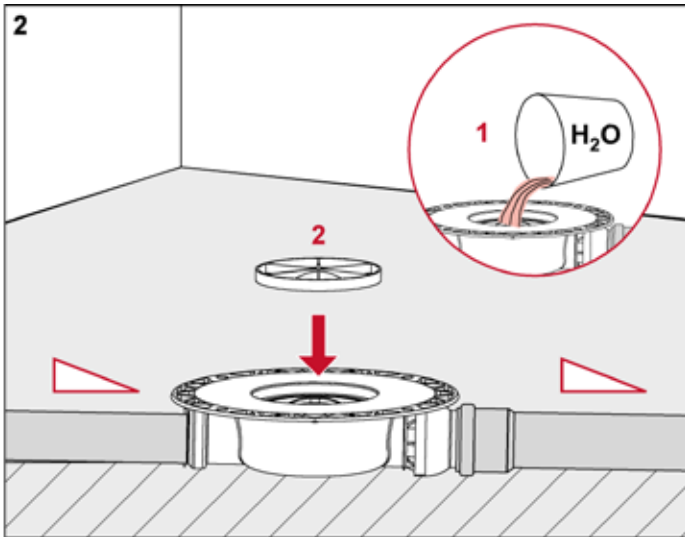

Carry out a leak test.

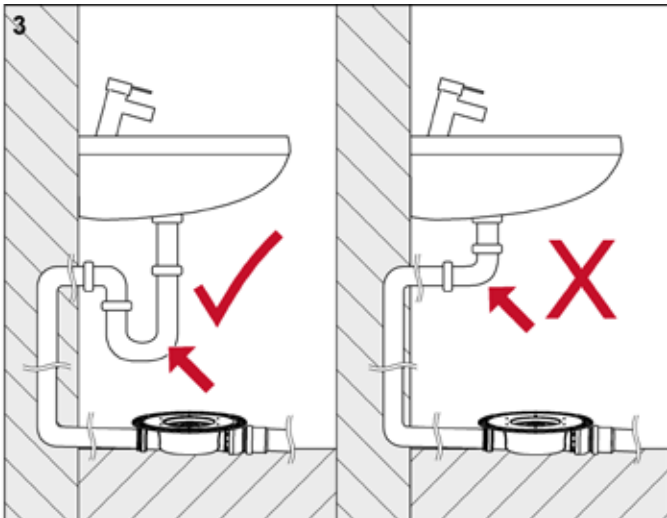

An odour trap is required in the inlet pipe when using the side inlet.

3-26

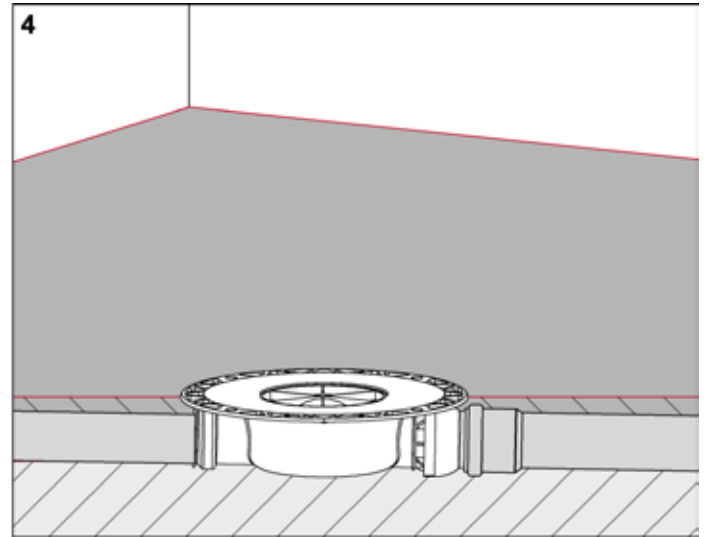

Apply the screed.

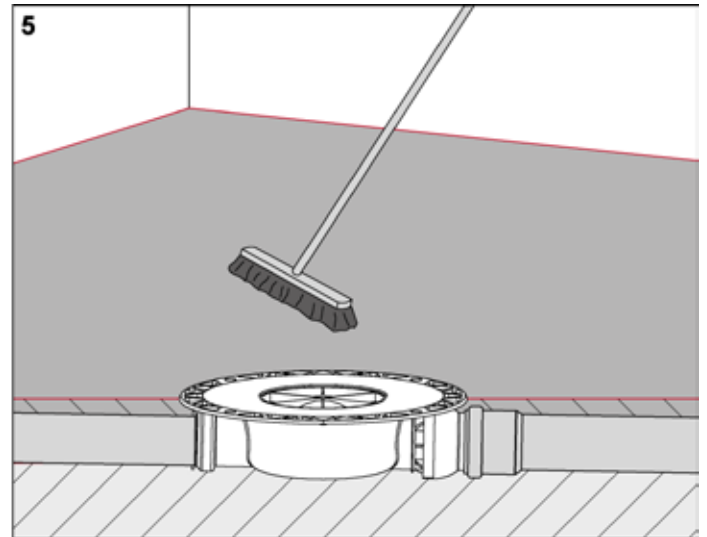

After drying, clean the screed.

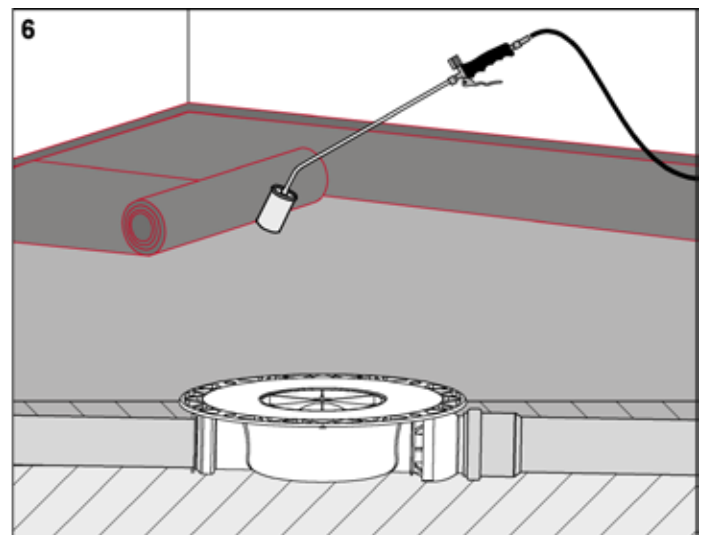

Apply sealing membranes (bitumen/EPDM) according to manufacturer's instructions.

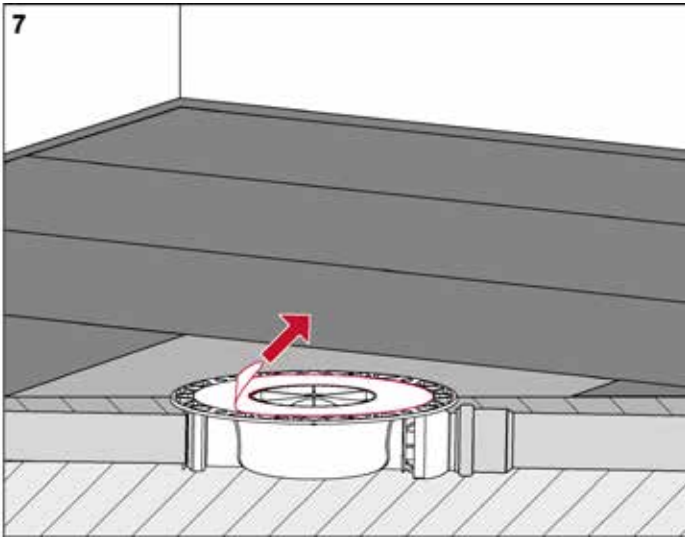

Remove protective foil from flange.

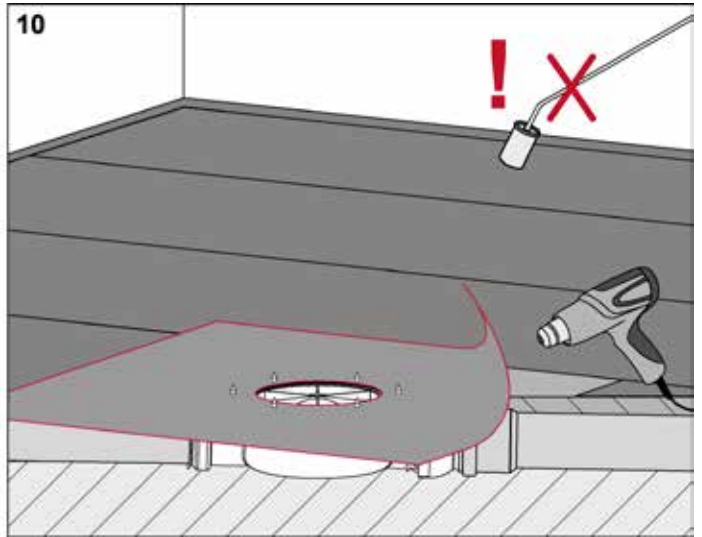

Weld the cut-to-size sealing foil to the sealing layer.

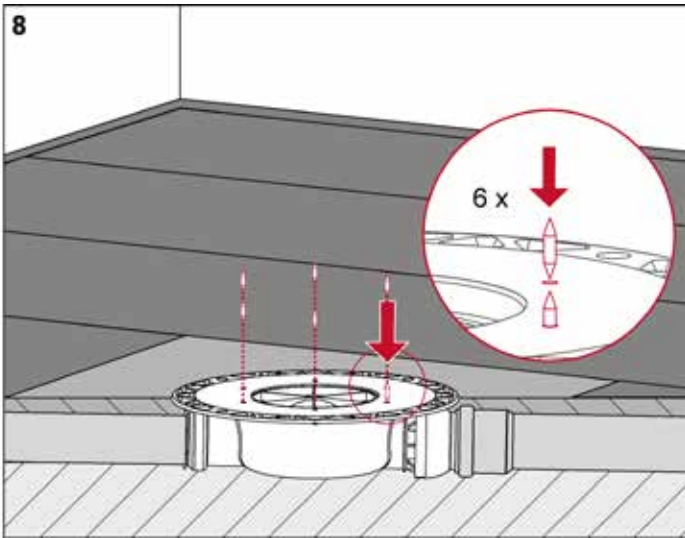

Insert pins for flange installation (6 x).

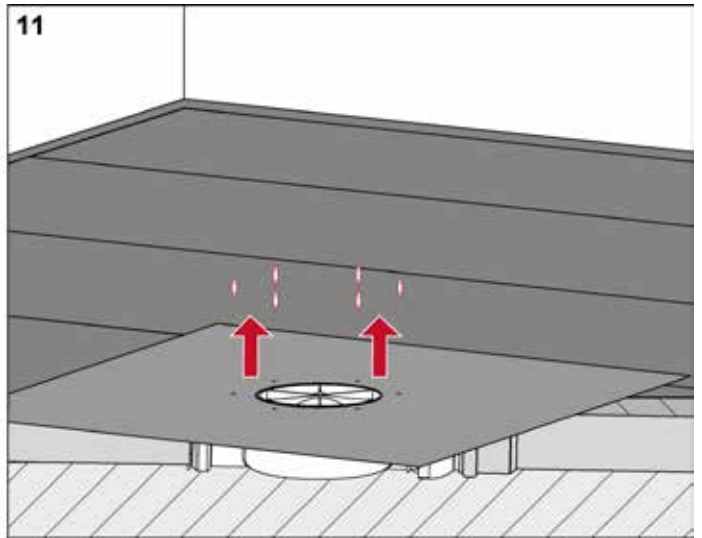

Remove pins.

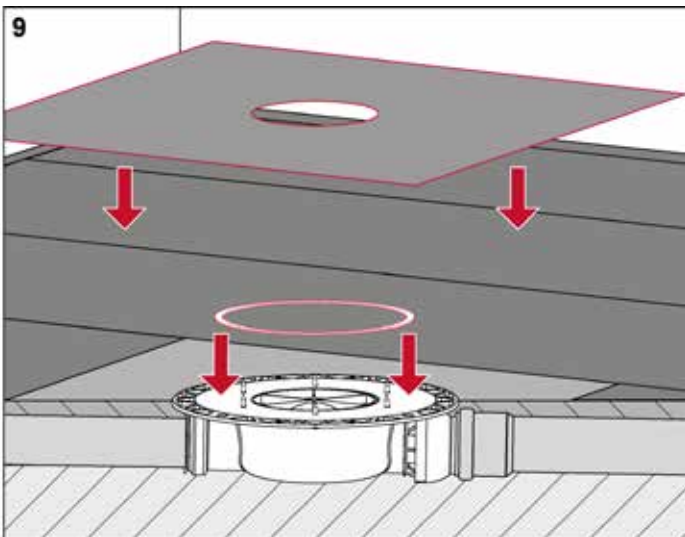

Place seal and fit sealing cut-to-size sealing foil (EPDM) exactly.

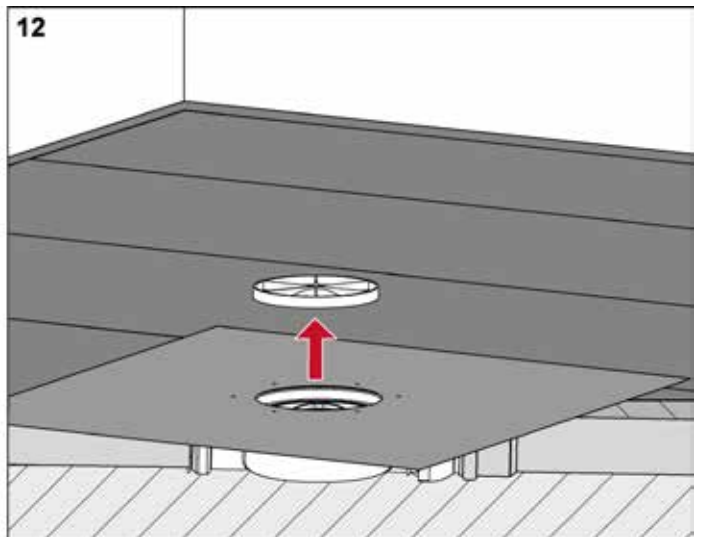

Remove construction time protection

Assembly instructions

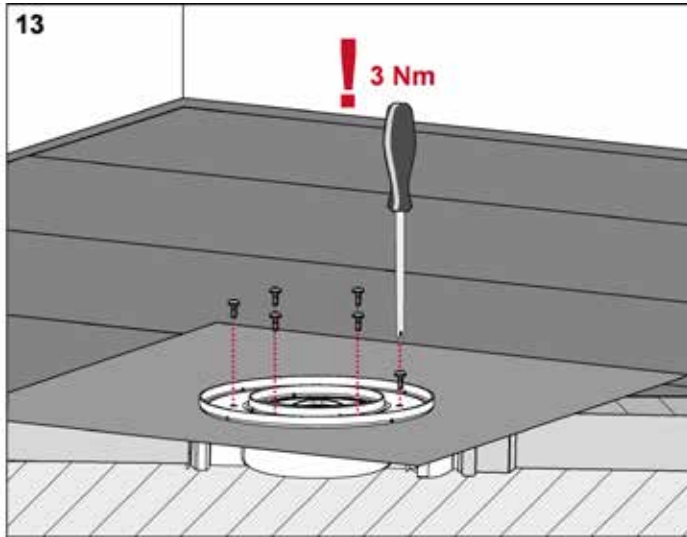

Screw on the compression ring (torque 3 Nm!)

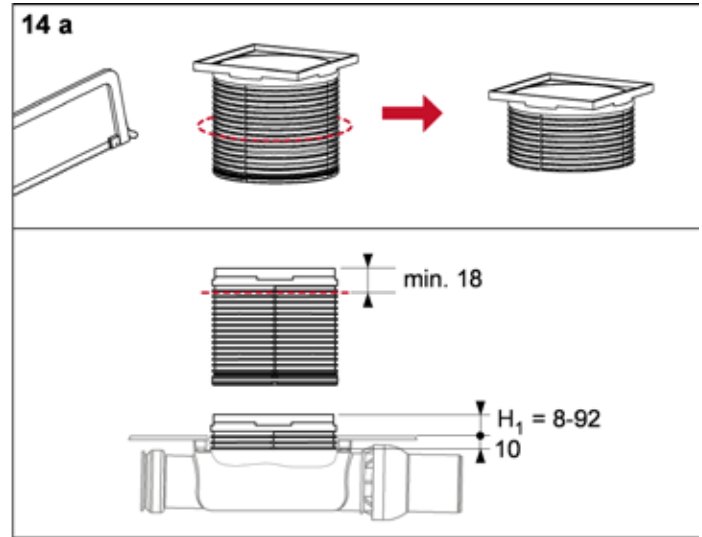

The drain top must be cut to the correct length.

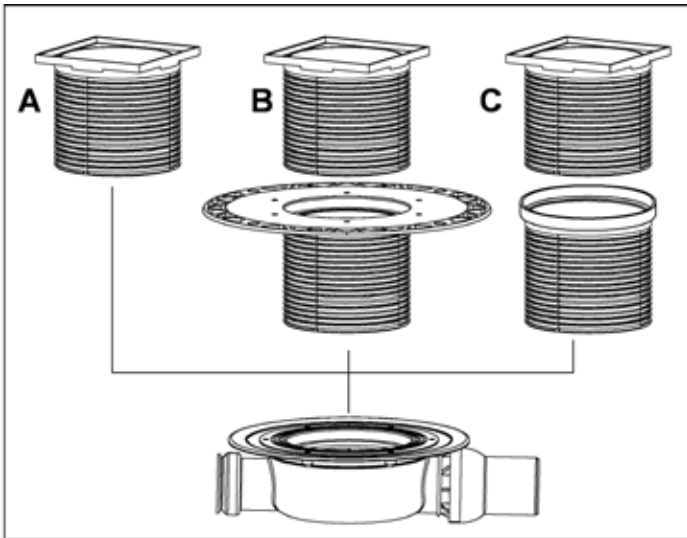

Different drain tops can be used.

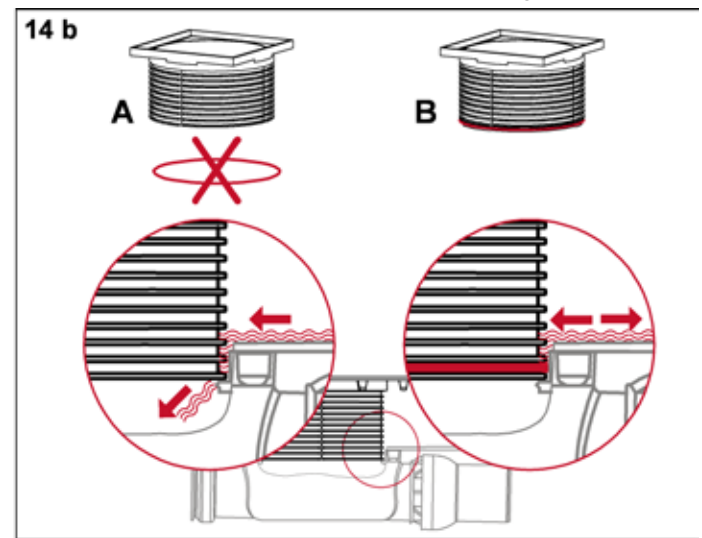

Seepage water drainage is guaranteed without an O-ring.

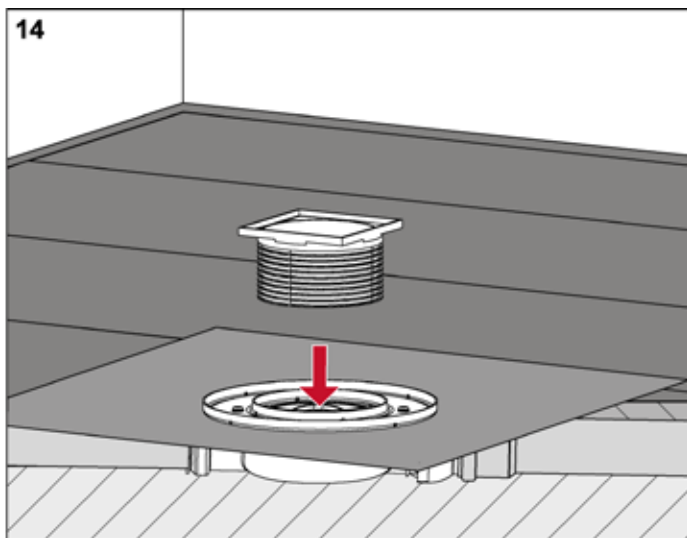

Push on the drain top.

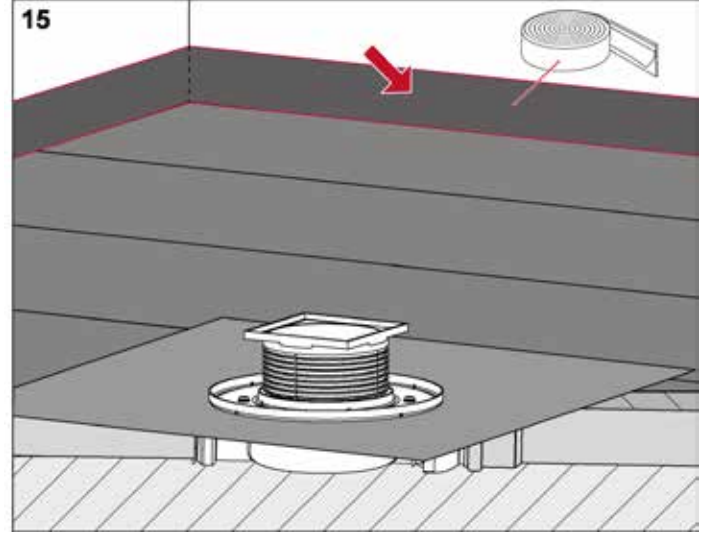

Attach the edge insulation strip

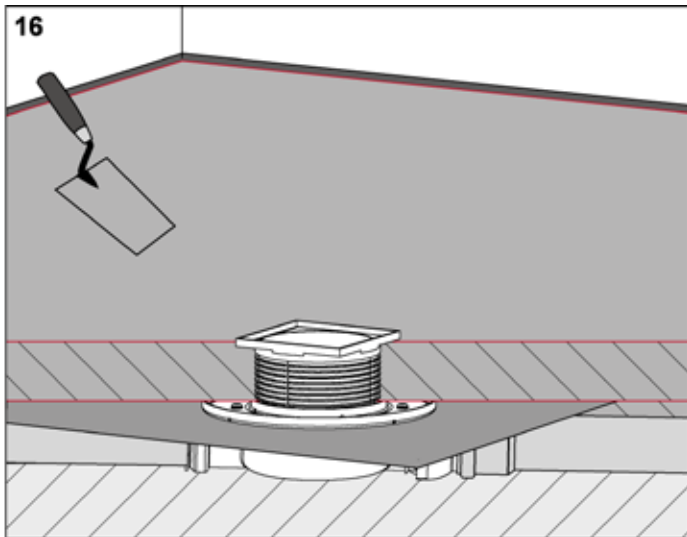

Apply the screed.

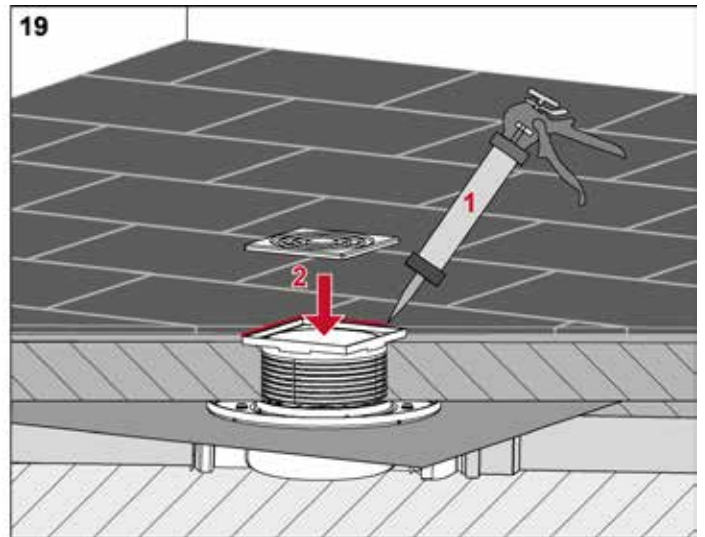

Seal the joint with permanently elastic material and insert grate.

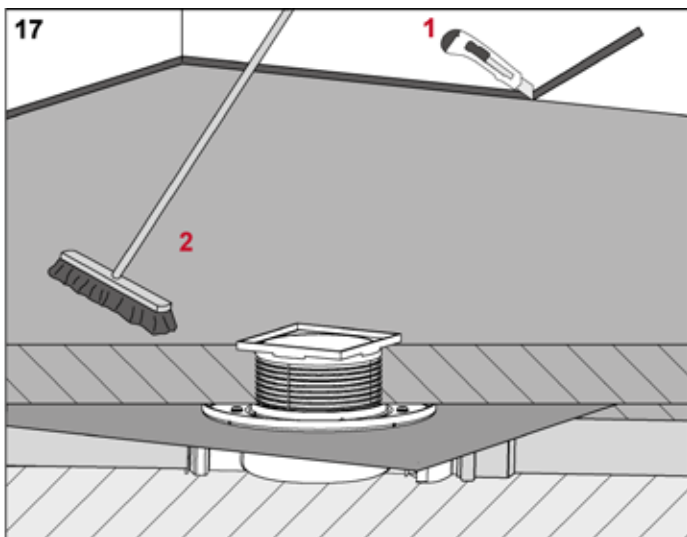

After drying, cut off the protruding edge insulation strip and PE foil, clean screed.

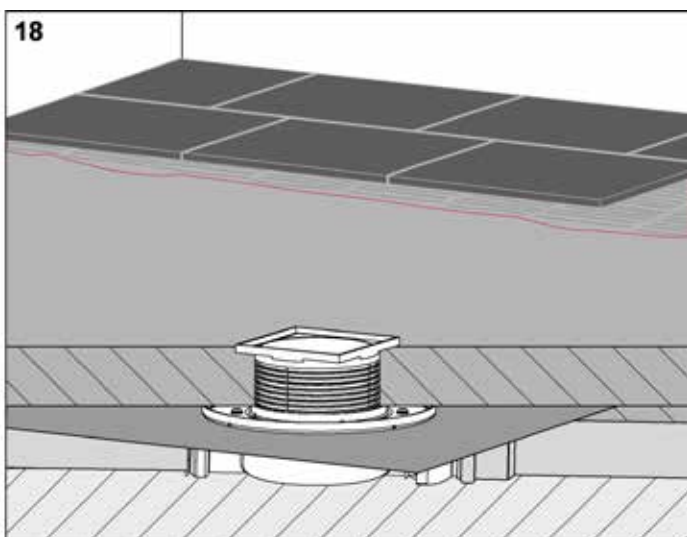

Apply the floor covering.

Assembly instructions

Installing the drain without flange

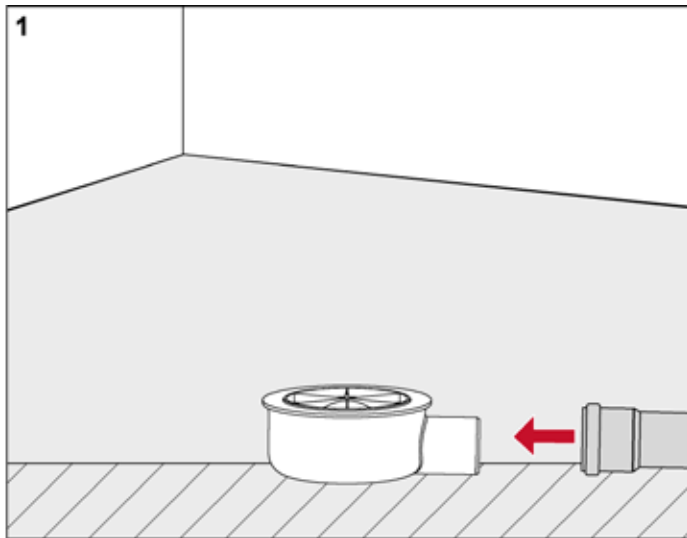

Position the floor drain and connect the sewer line.

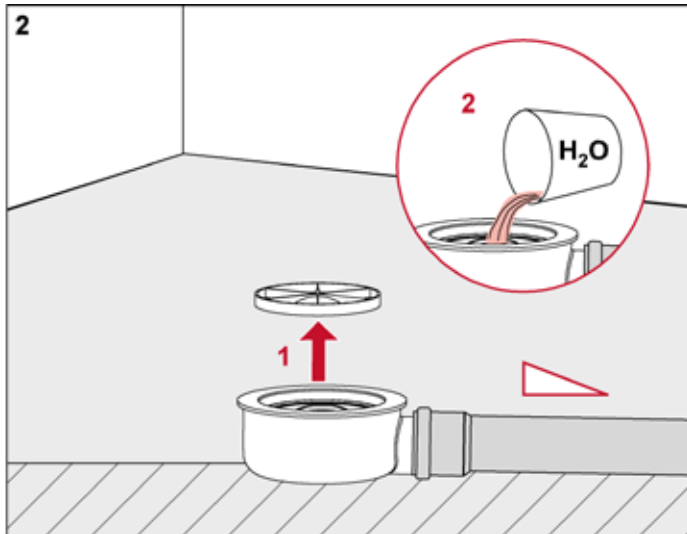

Carry out a leak test.

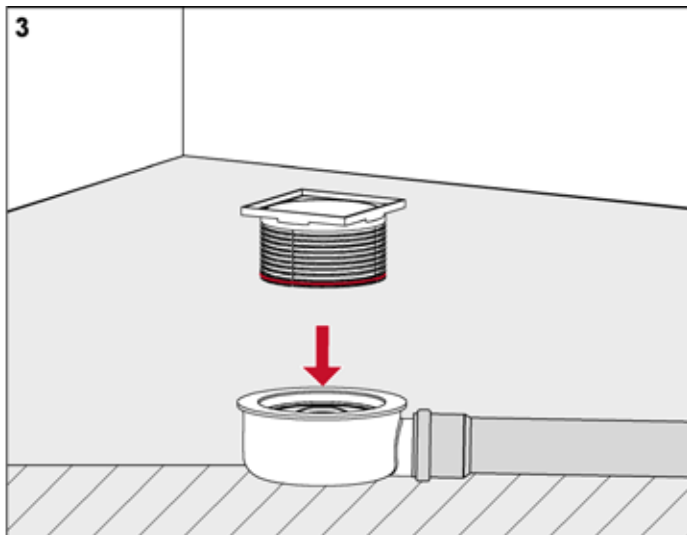

Push on the drain top.

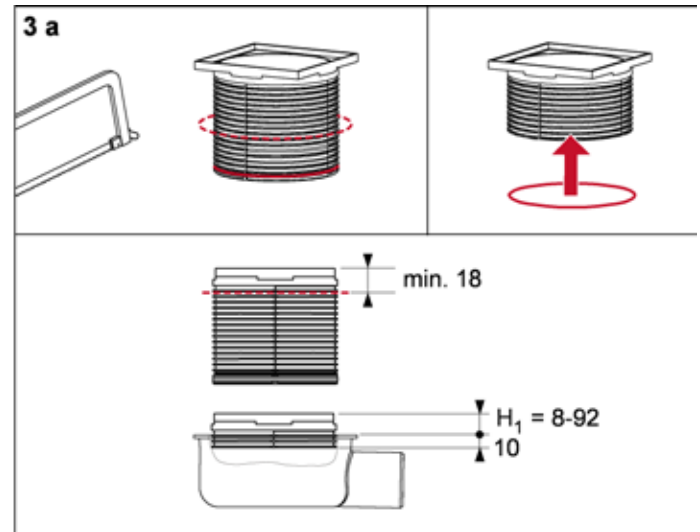

The drain top must be cut to the right length, the O-ring seal should be in the lowest groove.

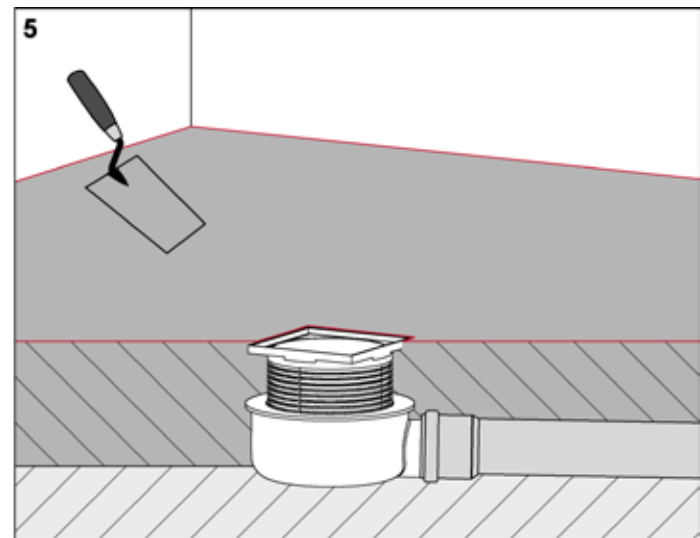

Place screed or other floor material.

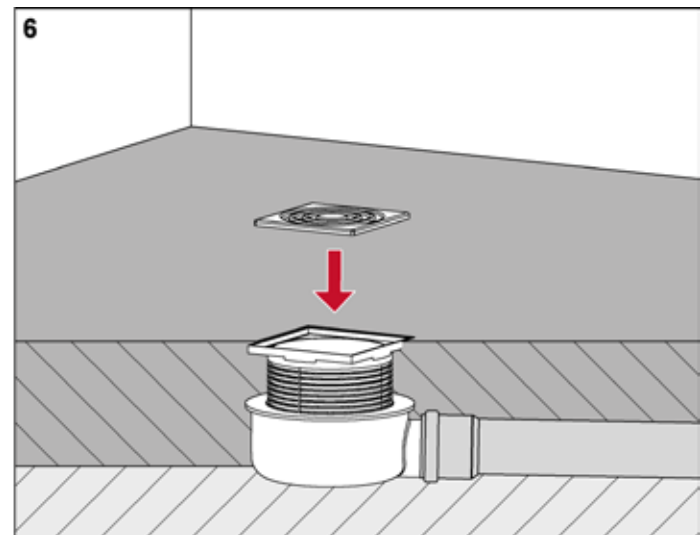

Insert grate.

Installing the “frameless” tile base

The “frameless” tile base is usually installed directly on a drain with a Seal System universal flange.

For installation, it is assumed that the drain has been installed and connected to the waste water side and that the seal has been made in accordance with regulations.

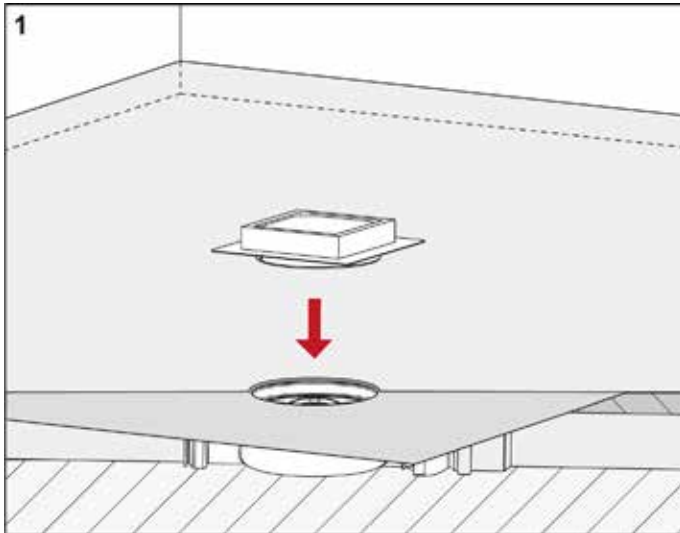

Insert and align the grate frame with bare-wall protection in the drain.

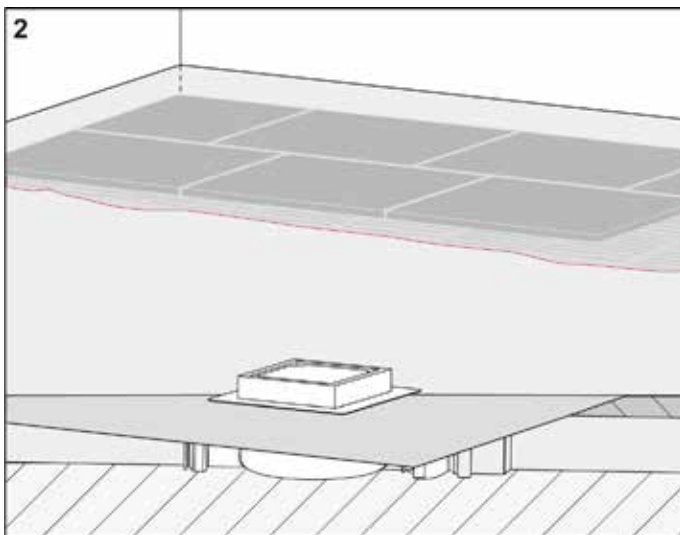

Apply the floor covering.

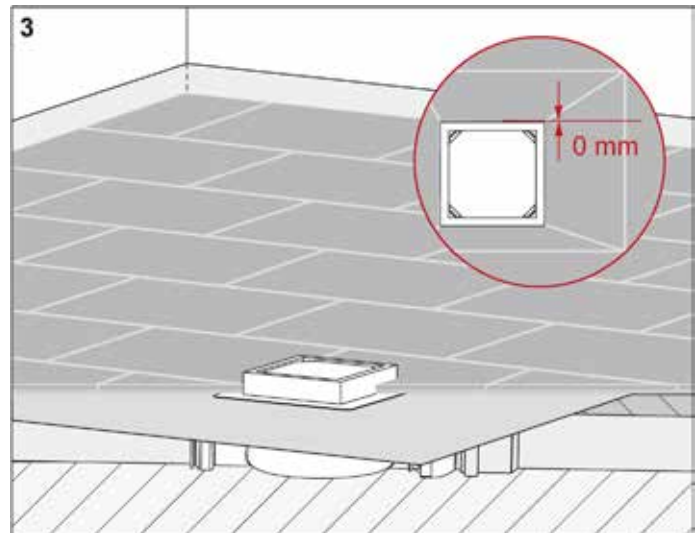

Apply the floor covering without spacing it from the bare-wall protection

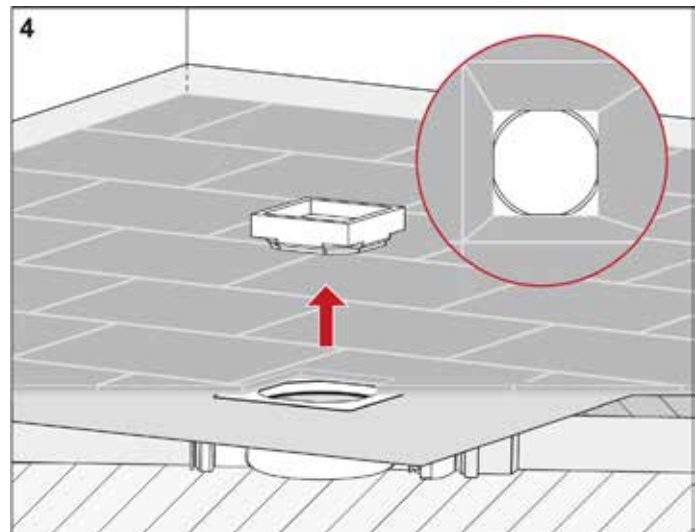

Remove the bare-wall protection.

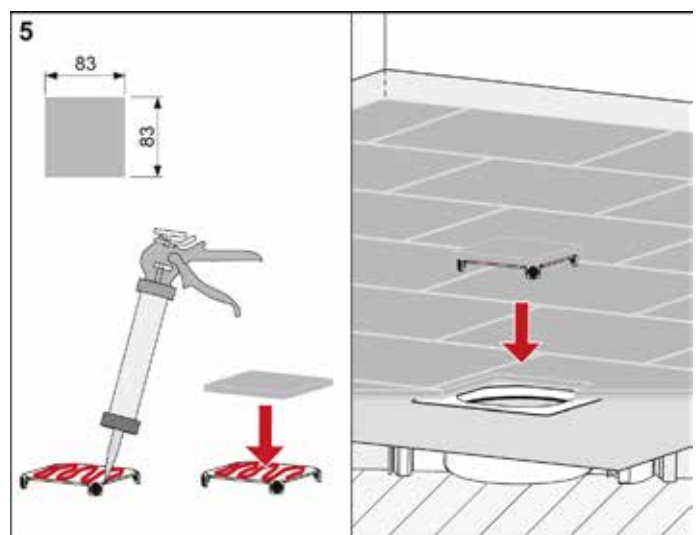

Cut the floor covering to size (approx. 83 x 83 mm) and glue it to the support with elastic adhesive (e.g. silicone or epoxy resin adhesive). After drying, insert the tile base in the grate frame.

Assembly instructions

Installing the tileable channel "plate"

The tileable channel is usually installed with a drain with a compression sealing flange and an extension piece.

For installation, the drain must be installed and connected to the waste water side and the seal must be made in accordance with regulations.

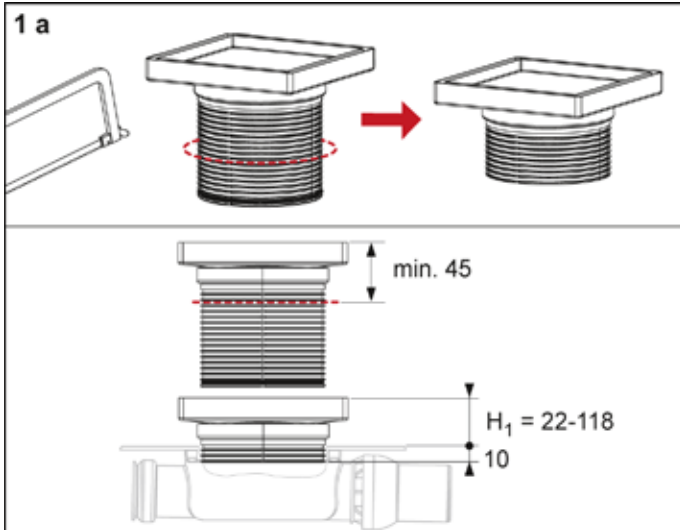
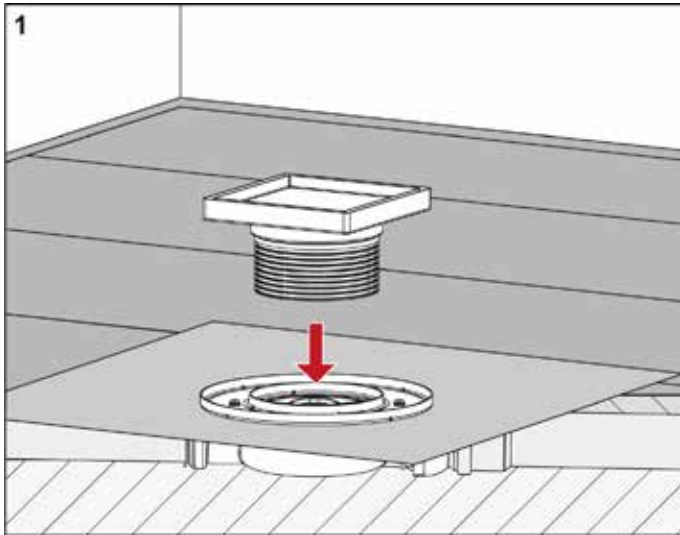

Attach the drain top – it must be cut to the correct length.

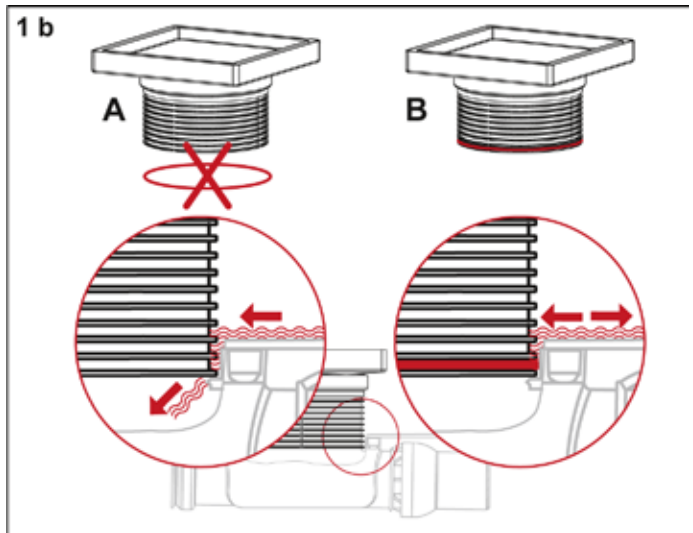

Seepage water drainage is guaranteed without an O-ring.

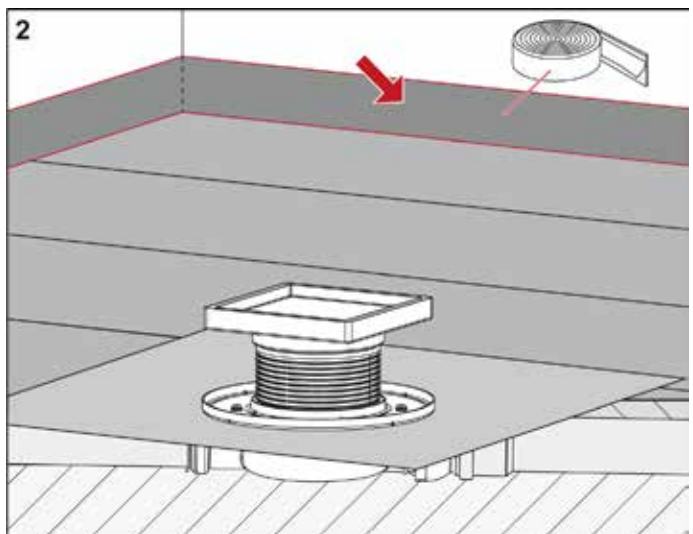

Attach the edge insulation strip.

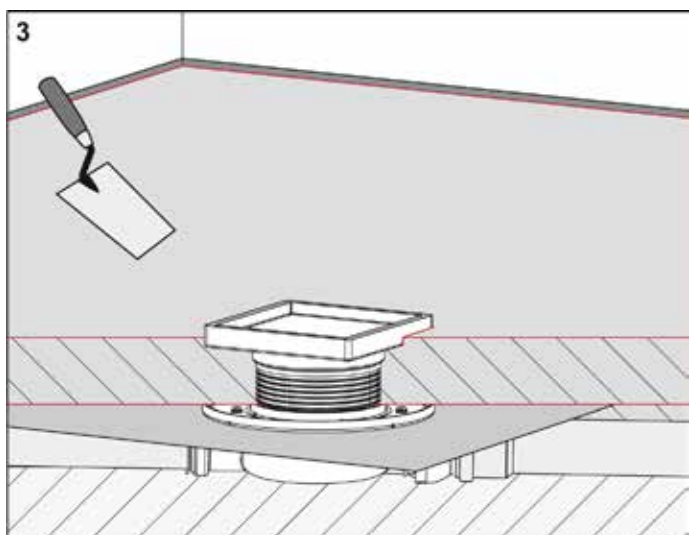

Apply the screed

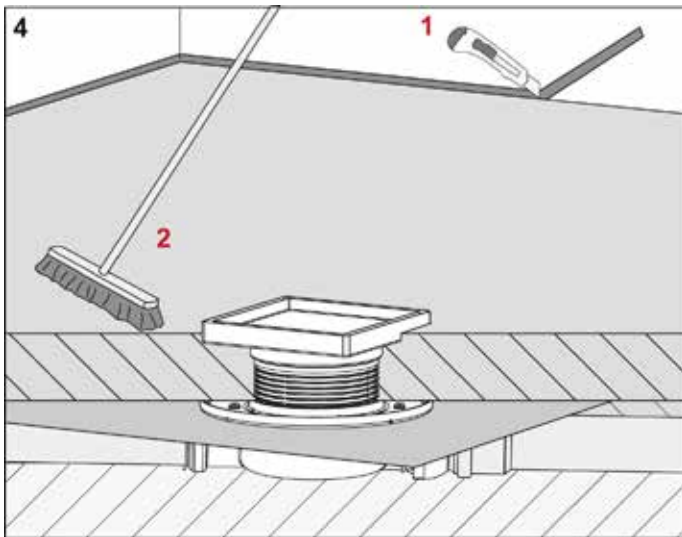

After drying, cut off the protruding edge insulation strip and PE foil, clean screed.

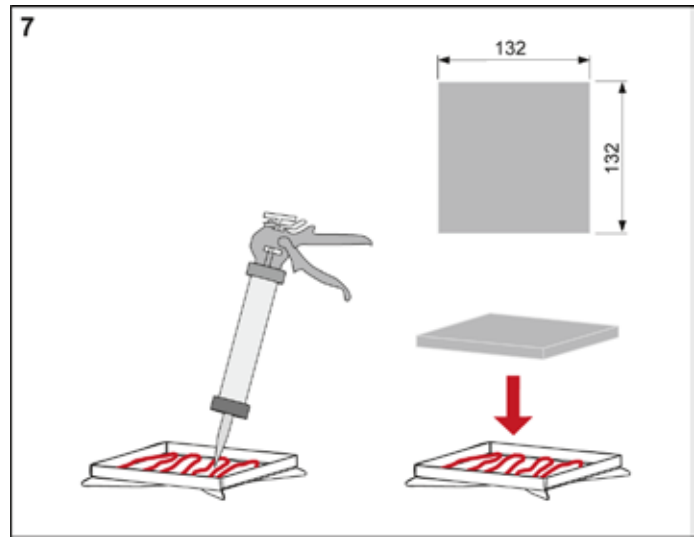

Cut the floor covering to size (approx. 132 x 132 mm) and glue it to the tileable channel with elastic adhesive (e.g. silicone or epoxy resin adhesive).

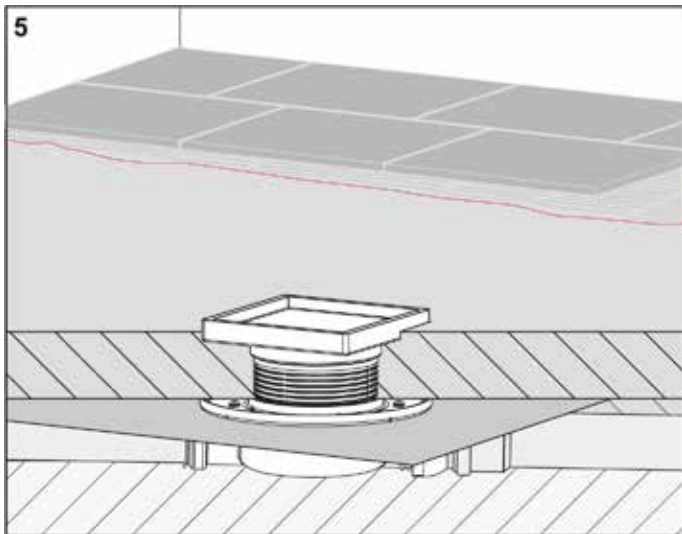

Apply the floor covering.

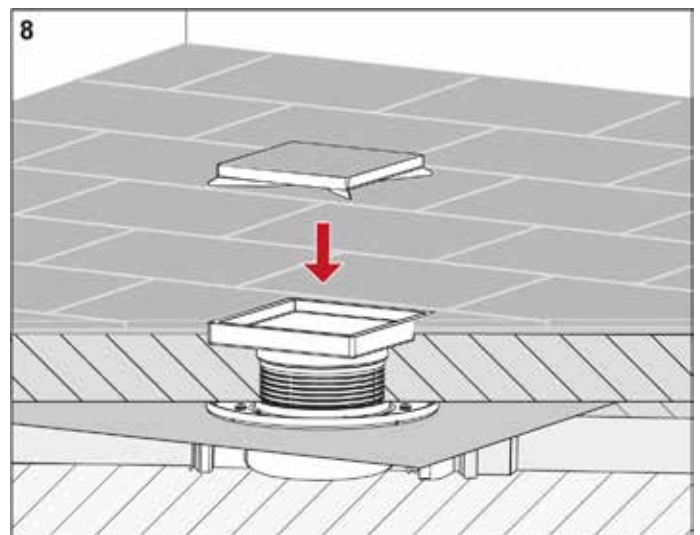

After drying, insert the tileable channel in the grate frame.

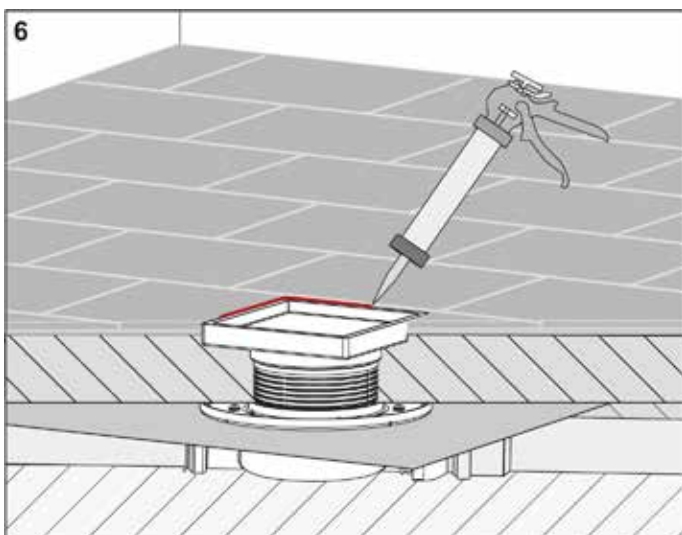

Seal the joint with permanently elastic material.

Assembly instructions